



**MODEL SHO-100-G**  
**Full-Size Gas Convection Oven**  
*(Formerly called SHO-G)*



**SHO-100-G**

Project \_\_\_\_\_

Item No. \_\_\_\_\_

Quantity \_\_\_\_\_

Standard depth baking compartment - accepts five 18" x 26" standard full-size baking pans in left-to-right positions.

All data is shown per oven section, unless otherwise indicated.

*Refer to operator manual specification chart for listed model names.*

**EXTERIOR CONSTRUCTION**

- Full angle-iron frame
- Stainless steel front, top, and sides
- Dual pane thermal glass window on left hand door, solid right hand door
- Tubular chrome handle with simultaneous door operation
- Triple-mounted pressure lock door design with turnbuckle assembly
- Removable front control panel
- Solid mineral fiber insulation at top, back, sides and bottom

**INTERIOR CONSTRUCTION**

- Double-sided porcelainized baking compartment liner (14 gauge)
- Aluminized steel combustion chamber
- Dual inlet blower wheel
- Five chrome-plated racks, eleven rack positions with a minimum of 1-5/8" (41mm) spacing

**OPERATION**

- Dual Flow Gas system combines direct and indirect heat
- Electronic spark ignition control system
- Removable dual tube burners
- Pressure regulator and manual gas service cut-off valve located in front control area
- Air mixers with adjustable air shutters
- Solid state thermostat with temperature control range of 200°F (93°C) to 500°F (260°C)
- Two speed fan motor
- 1/2 horsepower blower motor with automatic thermal overload protection
- Control area cooling fan

**STANDARD FEATURES**

- SSM - Solid state manual control with separate dials to control thermostat and timer
- 25" (635mm) adjustable stainless steel legs (for single units)
- 6" (152mm) adjustable stainless steel legs (for double sections)
- Draft diverter or draft hood for venting (select one)
- One year oven parts and labor warranty\*

*\* For all international markets, contact your local distributor.*

**OPTIONS AND ACCESSORIES**

(AT ADDITIONAL CHARGE)

- **Legs/casters/stands:**
  - 6" (152mm) seismic legs
  - 6" (152mm) casters
  - 4" (102mm) low profile casters (double only)
  - 25" (635mm) stainless steel stand w/rack guides
  - 29" (737mm) stainless steel, fully welded open stand with pan supports
- **Controls:**
- **Gas hose with quick disconnect and restraining device:**
  - 48" (1219mm) hose
  - 36" (914mm) hose
- Extra oven racks
- Gas manifold (for double sections)
- Flue connector



**BLODGETT OVEN COMPANY**

www.blodgett.com • 44 Lakeside Avenue, Burlington, VT 05401 • Phone: (802) 658-6600 • Fax: (802) 864-0183



# SHO-100-G

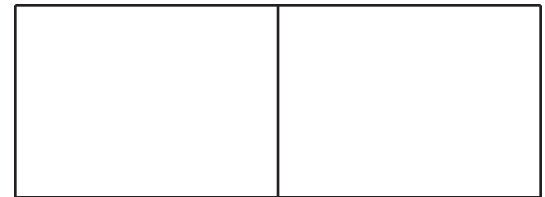

APPROVAL/STAMP

DIMENSIONS ARE IN INCHES (MM)

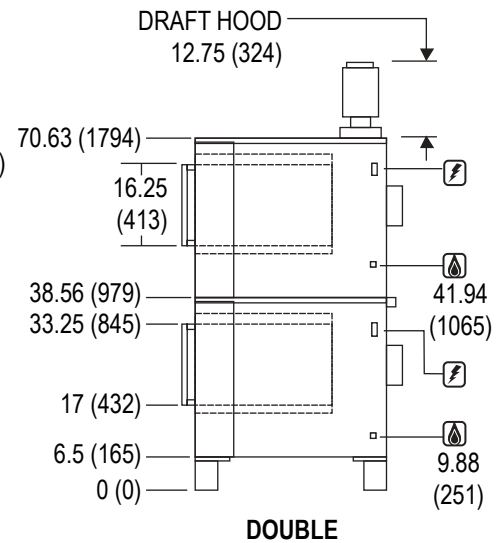
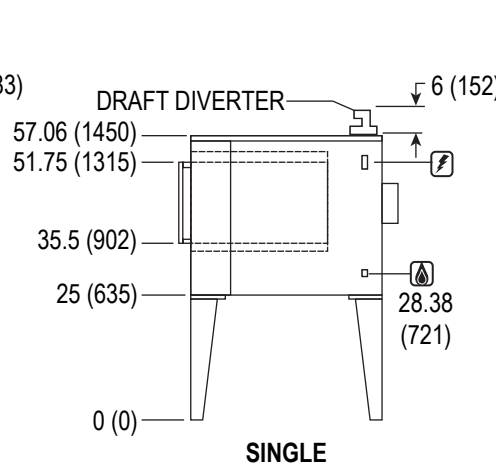
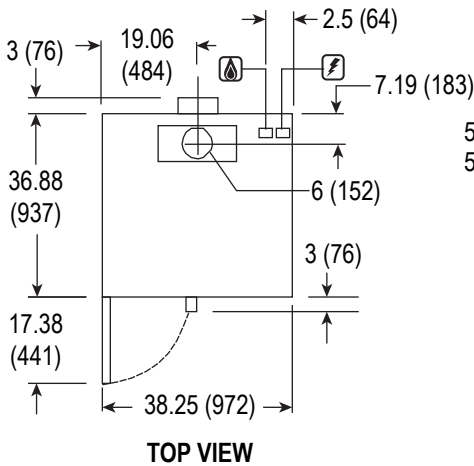

**SHORT FORM SPECIFICATIONS:** Provide Blodgett full-size convection oven model SHO-100-G, (single/double) compartment. Each compartment shall have (porcelainized/stainless) steel liner and shall accept five 18" x 26" standard full-size bake pans. Stainless steel front, top and sides. Right door shall be stainless steel, left door shall be stainless steel with dual pane thermal glass. Door shall have single tubular chrome handle and simultaneous operation. Unit shall be gas heated with electronic spark ignition and shall cook by means of a dual-flow system combining direct and indirect heat. Air in baking chamber distributed by dual inlet blower wheel powered by a two-speed, 1/2 HP motor with thermal overload protection. Each chamber shall be fitted with five chrome-plated removable racks. Control panel shall be recessed with Cook/Cool Down mode selector, solid state (manual/digital) infinite thermostat (200- 500°F), and 60-minute timer. Provide options and accessories as indicated.

**DIMENSIONS:**

- Floor space 38-1/4" (972mm) W x 36-7/8" (937mm) D
- Product clearance:**
- Oven Back 0" from combustible and non-combustible construction
- Oven Sides 2" from combustible and non-combustible construction
- Interior 29" (737mm) W x 20" (508mm) H x 24-1/4" (616mm) D
- If oven is on casters:**
- Single Add 4-1/2" (114mm) to all height dimensions
- Double Dimensions do not change
- Double Low Profile Subtract 2-1/2" (64mm) from all dimensions

**GAS SUPPLY:**

- 3/4" NPT
- Manifold Pressure:**
- Natural 3.5" W.C
- Propane 10" W.C.

**Inlet Pressure:**

- Natural 7.0" W.C. min. – 10.5" W.C. max.
- Propane 11.0" W.C. min. – 13.0" W.C. max.

**MAXIMUM INPUT:**

- Single 50,000 BTU/hr (14.6 Kw)
- Double 100,000 BTU/hr (29.2 Kw)

**POWER SUPPLY:**

- 115 VAC, 1 phase, 6 amp, 60 Hz., 2-wire with ground,
- 1/2 H.P., 2 speed motor, 1120 and 1710 RPM
- 6' (1.8m) electric cord set furnished on 115 VAC ovens only.
- Blodgett recommends a Pass & Seymour, model 2095, GFCI for this oven.

**MINIMUM ENTRY CLEARANCE:**

- Uncrated 32-1/16" (814mm)
- Crated 37-1/2" (953mm)

**SHIPPING INFORMATION:**

- Approx. Weight:**
- Single 535 lbs. (243 kg)
- Double 1070 lbs. (485 kg)

**Crate sizes:**

37-1/2" (952mm) x 43-1/2" (1105mm) x 51-3/4" (1315mm)

**NOTE:** The company reserves the right to make substitutions of components without prior notice

**BLODGETT OVEN COMPANY**

www.blodgett.com • 44 Lakeside Avenue, Burlington, VT 05401 • Phone: (802) 658-6600 • Fax: (802) 864-0183