



[C-U48R / C-U48F]



[C-U72R]



[C-U60R / C-U60F]



[C-U27R / C-U27F]

UNDER-COUNTER REFRIGERATORS & FREEZERS

- Beautiful Ergonomic Construction
- All Stainless Steel Exterior & Interior
- Recessed Door Handles
- Forced Air Refrigeration System
- Rear Mount Compressor
- Electro-mechanical thermostat
- (2) Locking, (2) Non-locking Casters
- 1 Year Parts & Labor Warranty
- 5 Years Compressor Warranty
- Refrigerators Temp Range: 33°F (~) 41°F
- Freezers Temp Range: -7°F (~) 0°F

Call Toll Free: 800 852 5292
 Web: www.migali.com

CERTIFICATIONS			MEDIA	
Conforms to NSF 7 Foodservice				

Model	Doors	Cu/Ft	Shelves	H/P	Amps	Voltage	Weight (lbs)	Energy Consumption Kwh/24Hr	Cabinet Construction WxDxH (inches)
REFRIGERATORS									
C-U27R	1	6.5	1	1/4	2.5	115/60/1	187	1.9	27.5 x 30 x 36.6
C-U48R	2	12	2	1/3	3.6	115/60/1	232	2.8	48.2 x 30 x 36.6
C-U60R	2	18	2	1/3	3.6	115/60/1	287	2.8	60.2 x 30 x 36.6
C-U72R	3	32.8	3	1/3	3.6	115/60/1	253	2.8	72.7 x 30 x 36.6
FREEZERS									
C-U27F	1	6.5	1	1/4	4.4	115/60/1	195	3.4	27.5 x 30 x 36.6
C-U48F	2	12	2	1/2	6.5	115/60/1	244	6.6	48.2 x 30 x 36.6
C-U60F	2	18	2	1/2	6.5	115/60/1	298	6.6	60.2 x 30 x 36.6

PLAN VIEWS

C-U72R

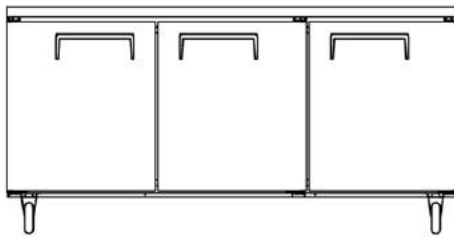
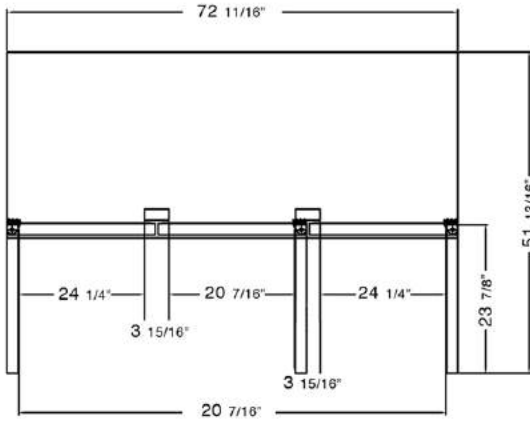

C-U60R
C-U60F

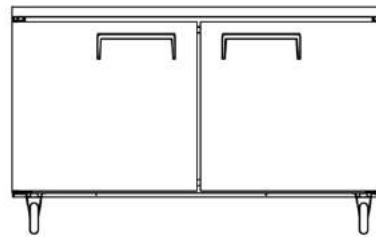
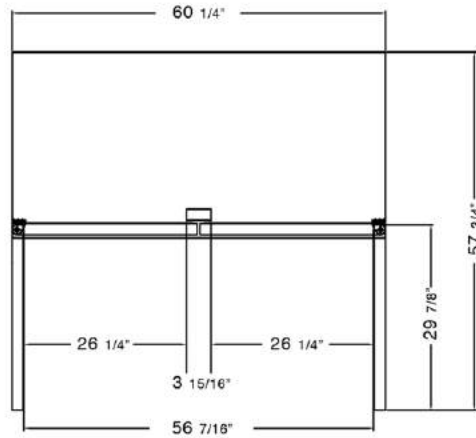

C-U48R
C-U48F

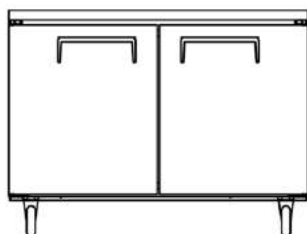
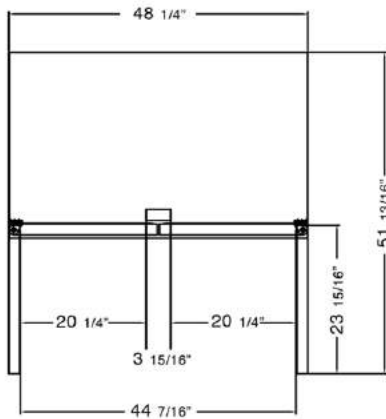

C-U27R
C-U27F

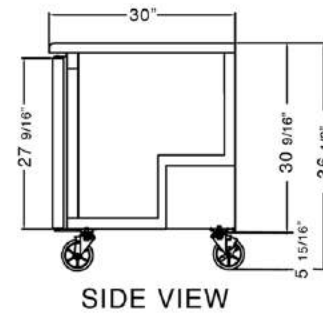
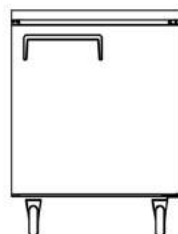
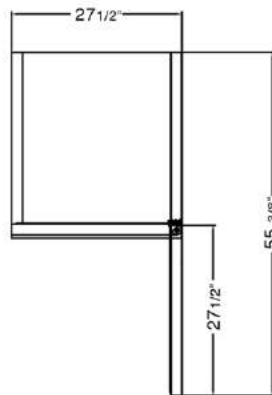

T: 800.852.5292
F: 856.963.3604
E: contact@migali.com
W: www.migali.com