



VEGETABLE PREPARATION MACHINE CA-31 120/60/1

Vegetable preparation machine. Production up to 1,000 lbs./hour.



P/N. 1050702



FEATURES AND BENEFITS

A perfect cut

- ✓ High precision adjustments to obtain a uniform and excellent-quality cut.
- ✓ It can be fitted with a wide range of discs and grids of the highest cutting quality. Combining these accessories together to obtain more than 70 different types of cuts and grating grades.

Built to last

- ✓ Made from stainless steel and food-grade materials of the highest quality: stainless steel motor block and food-grade aluminium head.
- ✓ High power asynchronous motor.

Maximum comfort for the user

- ✓ Ergonomic design: product sliced in one single movement.
- ✓ Lateral product output: requires less space on the worktop and guides the product, avoiding splashes.
- ✓ The electronic command panel is very intuitive.

Maintenance, safety, hygiene

- ✓ Lever and lid easily removable for cleaning purposes.
- ✓ Combination of safety systems: head, cover, power switch.
- ✓ Appliance certified by NSF International (regulations on hygiene, cleaning and materials suitable for contact with foods).
- ✓ 100% tested.

INCLUDES

- ✓ Single-speed motor block.
- ✓ Regular hopper.

ACCESSORIES

- FCC Curved Slicing Discs
- FCO Rippled Slicing Discs
- FFC Chipping Grids
- FMC Dicing Grids
- FCE Julienne Discs
- FR Shredding & Grating Discs
- Long vegetable attachment
- Disc and Grid Packs
- Disc and Grid Holder
- Stand-trolley
- Grid Cleaning Kit
- FC-D Slicing Discs
- SH Shredding & Grating Discs ::
NEW: Detachable without tools & dishwasher safe

SALES DESCRIPTION

Single-speed motor block + Regular hopper.



sammic | www.sammic.us
Food Service Equipment Manufacturer

usa@sammic.com phone +1 (224) 307-2232
1225 Hartrey Avenue toll free +1 844 275 3848
60202-1056 Evanston, IL



Project	Date
Item	Qty
Approved	

DYNAMIC PREPARATION
COMMERCIAL VEGETABLE PREPARATION MACHINES

product sheet
updated 12/30/19



VEGETABLE PREPARATION MACHINE CA-31 120/60/1

Vegetable preparation machine. Production up to 1,000 lbs./hour.



SPECIFICATIONS

Hourly production (pieces): 300 lbs. - 1000 lbs.

Inlet opening: 21 in2

Disc diameter: 8 "

Motor speed:365 rpm

Total loading: 1.5 Hp

Electrical supply: 120 V / 60 Hz / 1 ~ (4.3 A)

Plug: USA

Noise level (1m.): <70 dB(A)

Background noise: 32 dB(A)

External dimensions (WxDxH)

Width: 15.4 "

Depth: 16 "

Height: 21.4 "

Net weight: 46 lbs.

Crated dimensions

17.1 x 16.9 x 23.6 "

Volume Packed: 0.11 m³

Gross weight: 59.5 lbs.

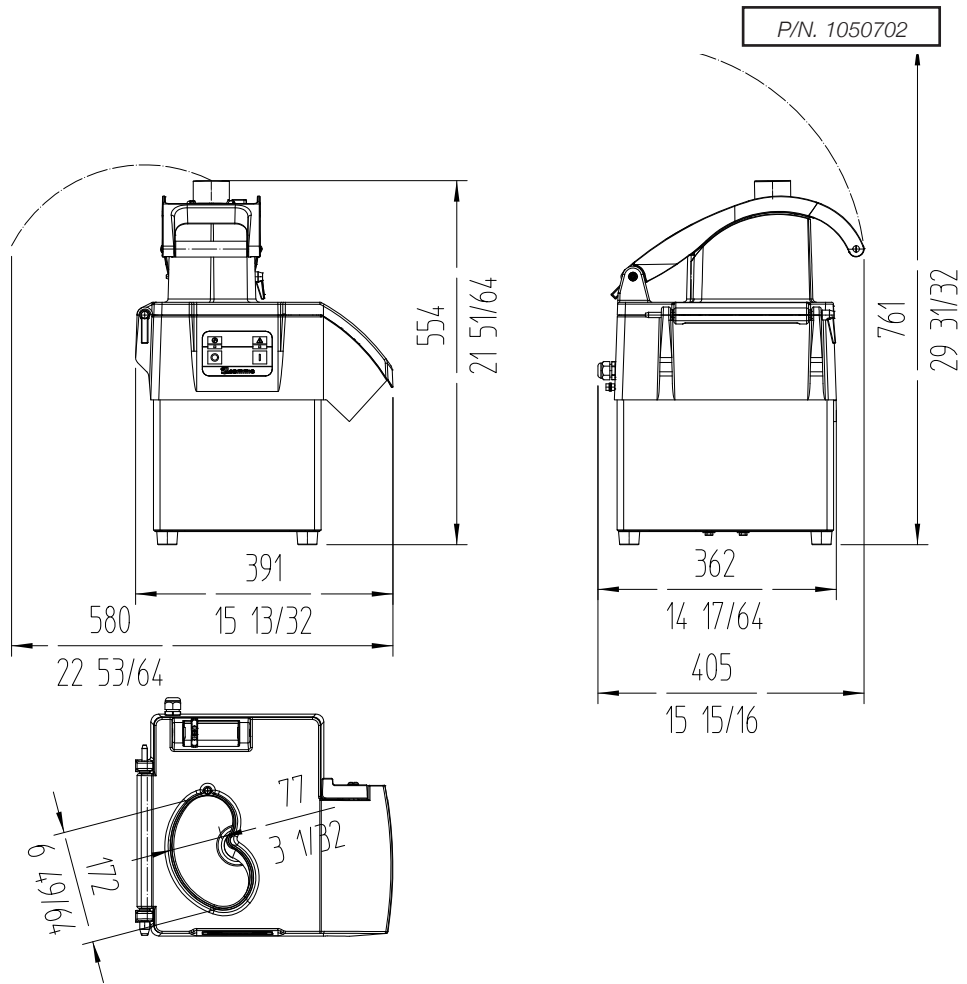

DYNAMIC PREPARATION
COMMERCIAL VEGETABLE PREPARATION MACHINES

sammic | www.sammic.us
Food Service Equipment Manufacturer

usa@sammic.com
1225 Hartrey Avenue
60202-1056 Evanston, IL

phone +1 (224) 307-2232
toll free +1 844 275 3848



Project	Date
Item	Qty
Approved	

product sheet
updated 12/30/19