



CORTADORA CA-41 120/60/1

High production vegetable preparation machine with an hourly output of up to 1,300 lbs.

P/N. 1050720



FEATURES AND BENEFITS

A perfect cut

- ✓ High precision adjustments to obtain a uniform and excellent-quality cut.
- ✓ It can be fitted with a wide range of discs and grids of the highest cutting quality. Combining these accessories together to obtain more than 70 different types of cuts and grating grades.
- ✓ Head with blade on one side that distributes products inside the mouth and cuts and distributes whole products such as cabbage.
- ✓ Head equipped with high ejector: enables a higher quantity of product to be shifted.

Built to last

- ✓ Made from stainless steel and food-grade materials of the highest quality: stainless steel motor block and food-grade aluminium head.
- ✓ High power asynchronous motor.

Maximum comfort for the user

- ✓ Ergonomic design. Maximum comfort for the user.
- ✓ Lateral product output: requires less space on the worktop and guides the product, avoiding splashes.
- ✓ The electronic command panel is very intuitive.

Maintenance, safety, hygiene

- ✓ Lever and lid easily removable for cleaning purposes.
- ✓ Combination of safety systems: head, cover, power switch.
- ✓ Appliance certified by NSF International (regulations on hygiene, cleaning and materials suitable for contact with foods).
- ✓ 100% tested.

INCLUDES

- ✓ 1 speed motor block.
- ✓ Core drill (optional use).
- ✓ Large capacity hopper.

ACCESSORIES

- FCC Curved Slicing Discs
- FCO Rippled Slicing Discs
- FFC Chipping Grids
- FMC Dicing Grids
- FCE Julienne Discs
- FR Shredding & Grating Discs
- Long vegetable attachment
- Universal hopper
- Disc and Grid Packs
- Disc and Grid Holder
- Automatic Hopper
- Grid Cleaning Kit
- FC-D Slicing Discs
- SH Shredding & Grating Discs ::
NEW: Detachable without tools & dishwasher safe

SALES DESCRIPTION

Single-speed motor block + large production attachment.

- ✓ Uniform, high-quality cut.
- ✓ Ergonomic design.
- ✓ Head with blade on one side that cuts and distributes products inside the mouth and distributes whole products such as cabbage.
- ✓ High ejector: processes a higher quantity of product, obtaining a high production without affecting the final quality.
- ✓ Lateral product output: requires less space on the worktop and guides the product, avoiding splashes.
- ✓ Lever and lid easily removable for cleaning purposes.
- ✓ Accredited by NSF International.



sammic | www.sammic.us
Food Service Equipment Manufacturer

usa@sammic.com phone +1 (224) 307-2232
1225 Hartrey Avenue toll free +1 844 275 3848
60202-1056 Evanston, IL



Project	Date
Item	Qty
Approved	



DYNAMIC PREPARATION
COMMERCIAL VEGETABLE PREPARATION MACHINES

product sheet
updated 12/30/19



CORTADORA CA-41 120/60/1

High production vegetable preparation machine with an hourly output of up to 1,300 lbs.



SPECIFICATIONS

Hourly production (pieces): 400 lbs. - 1300 lbs.

Inlet opening: 44.4 in2

Disc diameter: 8 "

Motor speed: 365 rpm

Total loading: 1.5 Hp

Electrical supply: 120 V / 60 Hz / 1 ~ (4.3 A)

Plug: USA

Noise level (1m.): <70 dB(A)

Background noise: 32 dB(A)

External dimensions (WxDxH)

Width: 15.4 "

Depth: 15.6 "

Height: 25.7 "

Crated dimensions

17.3 x 16.9 x 27.6 "

Volume Packed: 0.13 m³

Gross weight: 63.9 lbs.

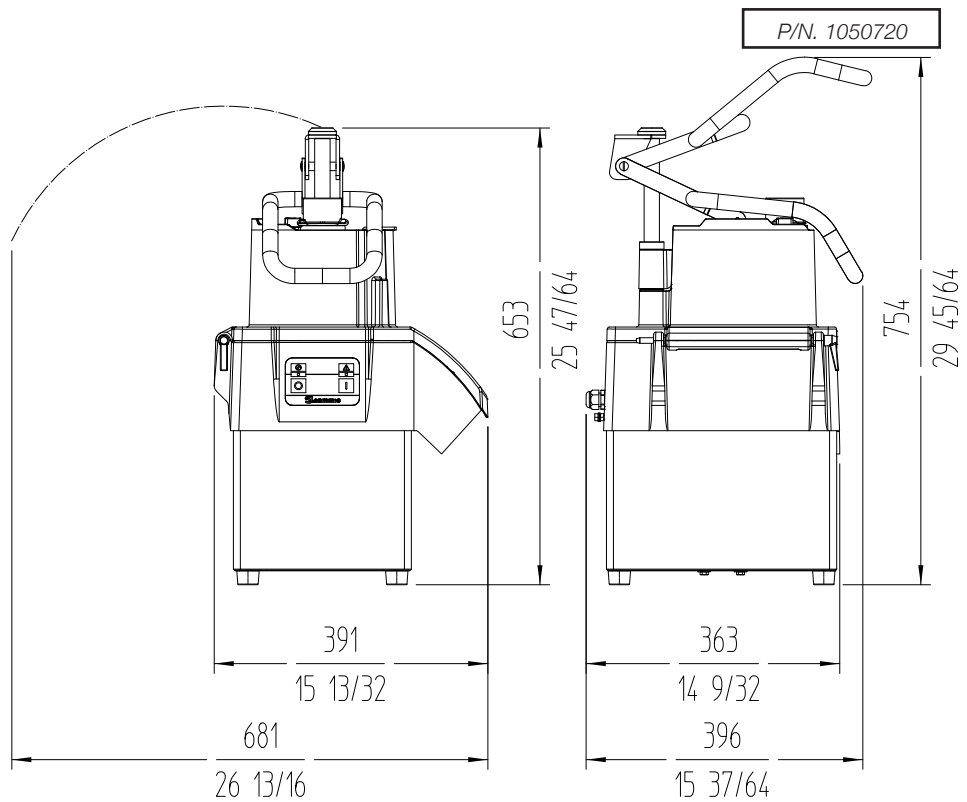

DYNAMIC PREPARATION
COMMERCIAL VEGETABLE PREPARATION MACHINES

sammic | www.sammic.us
Food Service Equipment Manufacturer

usa@sammic.com phone +1 (224) 307-2232
1225 Hartrey Avenue toll free +1 844 275 3848
60202-1056 Evanston, IL



Project	Date
Item	Qty
Approved	

product sheet
updated 12/30/19