

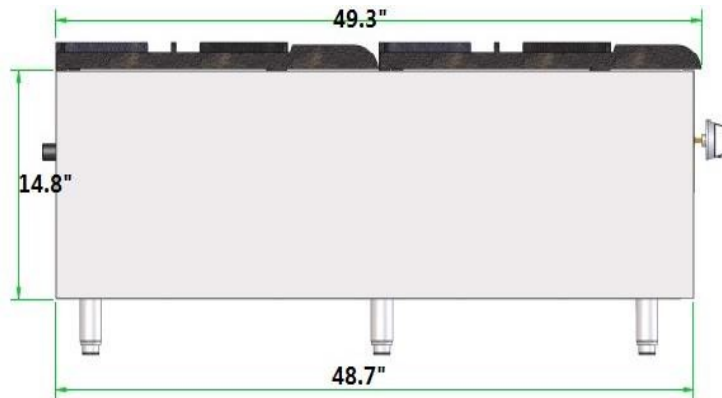

Est.1838 • Commercial Cooking Equipment

# STOCK POT STOVE

## CCSP Series

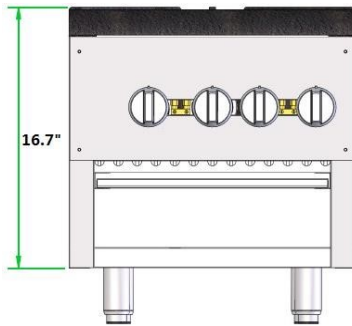
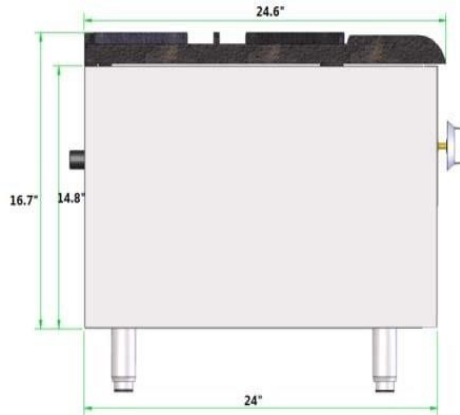
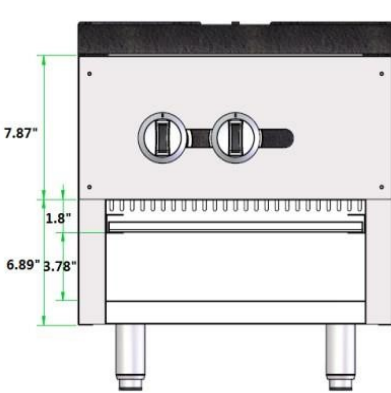

### Standard Features, Benefits & Options

**CONSTRUCTION:** Heavy gauge welded and bolted frame for rugged usage. Standard finish is easy cleaning stainless steel on all exterior surfaces. 7" heavy duty stainless steel legs with adjustable feet up to an additional 2".

**CONTROLS:** Castle stock pot stoves are equipped with brass gas valves, automatic standing pilots, pressure regulators and cool to the touch control knobs.

**BURNERS:** CCSP models feature long life double venturi, cast iron burners rated up to a total of **110,000 BTUs**.

**TOP GRATES:** Heavy duty one piece cast iron with cast in bull nose. designed to accommodate pots as large as 14"-24" in diameter.

**TESTING:** The gas system is tested before shipment. Optimal pressure is 4" WC for natural gas, 10" WC for propane.

**ACCESSORIES & OPTIONS:** Gas hoses, wok rings and set screw knobs.

Model Number	Width x Depth		Burner Sections	Total BTU	Ship Weight	
	in	mm			lbs.	kgs.
CCSP1	18" x 24"	457 x 610	1	110,000	95	43.2
CCSP2	18" x 49"	457 x 1245	2	220,000	275	125



Comstock-Castle Stove Co. • 119 W. Washington St. • Quincy, IL. 62301  
 Tel.: 217-223-5070 • Fax.: 217-223-0007 • Web: www.castlestove.com

