

MAXIMIZER

Pizza Ovens

MODEL CE231PESC

General Features:

- **Quality Construction**
for long life
- **Stainless steel front**
Standard
- **Large capacity**
2,736 sq. inches of available
cooking space on six (6),
cordierite decks. Holds six (6)
18" pizzas
- **Unique interior design**
Better distribution of heat
- **Energy efficient**
Energy-saving tubular
elements coupled with
our unique baffle system for
even heat and better baking
- **Full Range Digital Control**
300°F - 650°F thermostat
(149°C - 343°C)
- **Solid State Relay**
Precise temperature control
- **Silent Operation**
- **Easily Serviceable**
All controls can be replaced
from the side of the unit
- **Power**
Electric - Single phase standard
Three phase optional

2-2-2 Warranty:

- **Two year parts**
- **Two year labor**
- **Two year trouble free service**



ELECTRIC



MORE FOR LESS

More Cooking Space per Floor Space
More Cooking Capacity per Sales Dollar
More Performance per Gas Dollar

 **Peerless**
Commercial and Industrial Ovens

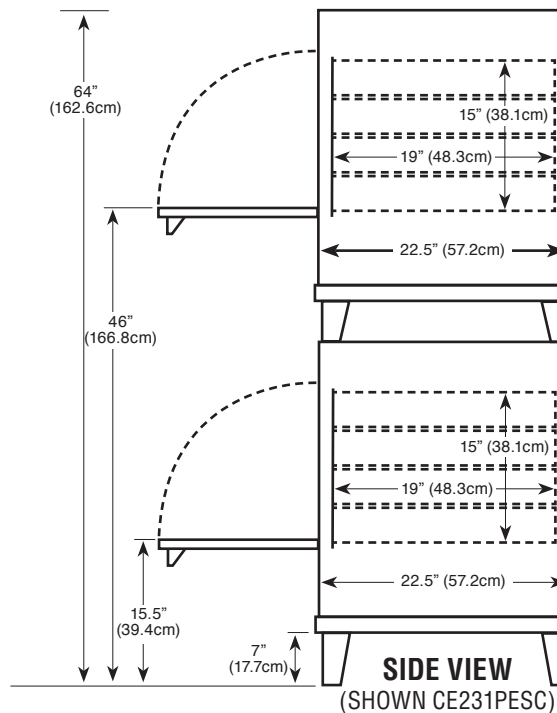
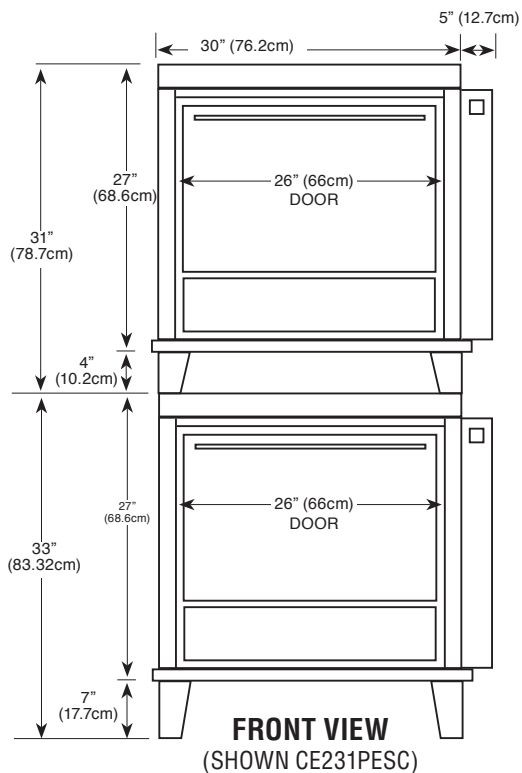

Counter space	35" (88.9cm) wide x 22.5" (57.2cm) deep* x 64" (162.6cm) high
High Shelf size	24" (61cm) wide x 19" (48.3cm) deep
Shipping weight	640 lbs (290kg)
Capacity	six 18" (40.7cm) pizzas
Electric	17 KW - 220V single phase 80 AMPS
Opening required for installation: 30" * Handle adds 2.5" (6.4cm) to depth	



Digital Electronic Controller
(Electric Models)



Adjustable Legs

Durable Construction

The CE231PESC is built with *prime 20-gauge cold-rolled sides* and topped with a 16-gauge base. The *interior is made of Armco Type 1, 20-gauge aluminized steel*. Also, the CE231PESC comes standard with a stainless steel front using high quality 18-gauge stainless steel.

Energy Efficiency

The CE231PESC is equipped with eight (8) energy saving tubular elements and with our unique baffle system, makes the oven highly efficient and eliminates hot spots. The heavily insulated walls coupled with a no vent system, reduces heat loss and keeps the area safe for workers. The CE231PESC is well powered by 14,000 watts, which enables it to have an extremely fast recovery rate.

Versatility

The CE231PESC comes with six (6) shelves and adequate spacing, which increases the oven's capabilities for either baking or roasting. This counter top unit is a double stack for double the capacity, double the efficiency and double the profits.

Capacity

The CE231PESC is the only *double-door, six shelf* pizza electric oven available. Each CE131PE houses *three (3) cordierite decks* which offers 912 square inches (5883.8 sq cm) of cooking area per shelf. That equals *2736 total square inches (17,651.8 sq cm) per oven*. When you compare the cost per shelf or per square inch to other ovens, Peerless is by far the greatest value.

Design Plus

The CE231PESC has a digital controller for ease of operation, to save space and in their very own air conditioned area so they are not affected by outside influences. All controls can be replaced from the side of the unit. The CE231PESC is also available in a two shelf version if interior space is an issue. Call for details.

