

# MAXIMIZER

## Pizza Ovens

MODEL CE61PE

### General Features:

- **Quality Construction**  
for long life
- **Stainless steel front**  
Standard
- **Large capacity**  
2,688 sq. inches of available  
cooking space. Holds  
(8) eight 16" pizzas
- **Pizza Stones**  
Standard
- **Unique interior design**  
Better distribution of heat
- **Energy efficient**  
Energy-saving tubular  
elements coupled with  
our unique baffle system for  
even heat and better baking
- **Full Range Digital Control**  
300°F - 650°F thermostat  
(149°C - 343°C)
- **Solid State Relay**  
Precise temperature control
- **Space Saver**  
Only 50" wide
- **Silent Operation**
- **Easily Serviceable**  
All controls can be replaced  
from the front of the unit
- **Power**  
Single phase standard  
Three phase optional
- **Top Heat Control**  
Balances oven heat

**NEW  
Feature!**

### Warranty:

**One year parts and labor**



**ELECTRIC**



### MORE FOR LESS

More Cooking Space per Floor Space  
More Cooking Capacity per Sales Dollar  
More Performance per Dollar

**Peerless**  
Commercial and Industrial Ovens

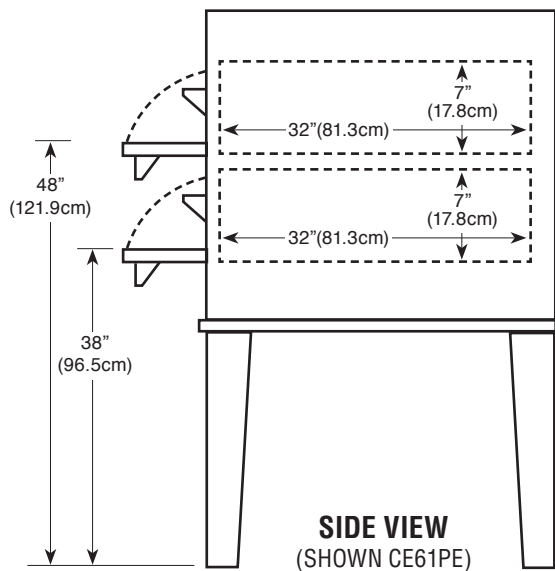
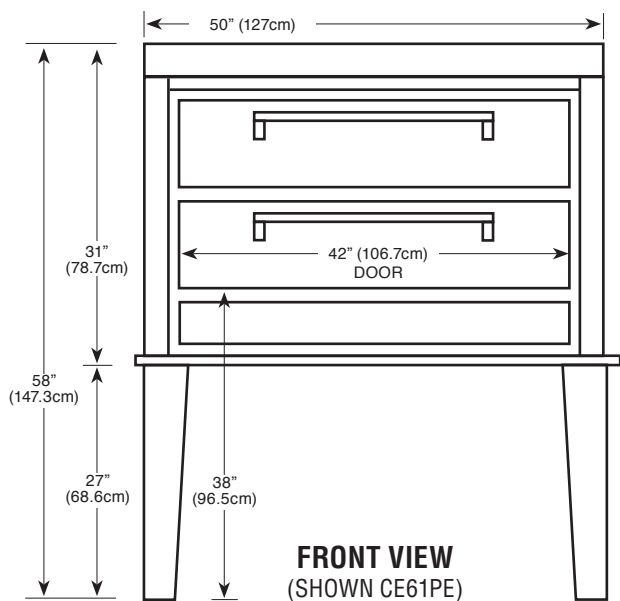

Floor space . . . . .	50"(127cm) wide x 42"(105cm) deep* x 58"(147.3cm) high
Shelf size . . . . .	42"(106.7cm) wide x 32"(81.3cm) deep x 7"(17.8cm) high
Shipping weight . . . . .	850 lbs (385.6kg)
Capacity for CE61PE . . . . .	Twelve 12" (30.5cm) pizzas or eight 16" (40.7cm) pizzas
Electric . . . . .	.12KW - 220V single phase 60 AMPS
Opening required for installation: 32"                      * Handle adds 2.5"(6.4cm) to depth	



Digital Electronic Controller



Adjustable Legs

**Durable Construction**

The CE61PE is built with *prime 20-gauge cold-rolled top and sides* with a 14-gauge base. The *interior is made of Armco Type 1, 20-gauge aluminized steel*. The CE61PE comes standard with a stainless steel front made of high quality, 18-gauge stainless steel; the door interior is 18 gauge stainless as well.

**Energy Efficiency**

The CE61PE is equipped with six (6) energy saving tubular elements and with our unique baffle system, makes the oven highly efficient and eliminates hot spots. The heavily insulated walls coupled with a no vent system, reduces heat loss and keeps the area safe for workers. The CE61PE is well powered by 12,000 watts, which enables it to have an extremely fast recovery rate.

**Capacity**

The CE61PE deck size measures 42"x32"x7" (2) decks in one oven. The top deck cooks almost as fast - and as well - as the bottom, providing outstanding capacity for your money. Actual cooking capacity depends on the size of the pizza you are cooking. The CE61PE will hold **twelve (12)** 12" pizzas, **eight (8)** 16" pizzas, or **six (6)** 18" pizzas. Cooking time will vary according to product, but will average between 8-10 minutes.

**Space Saver**

Because the controls are under the doors, the CE61PE requires *less installation space* than our competition. This enables you to free up valuable kitchen and/or hood space. The actual width needed is mere 50" for **42"x32"x7" (2) decks**, almost a foot less than the competition. The CE61PE *can convert into a CE62PESC by stacking\**, either initially or after your business grows. This option gives you four (4) 42"x32" decks in only 56" of space. (**\*will increase width**)

**Design Plus**

The CE61PE has digital *controls in lower front for ease of operation and space savings*. This also places the controls in their own *air-conditioned area* so they are not affected by outside influences. In addition, the CE61PE has a new feature: *adjustable top heat control to balance heat between upper and lower decks*.

