



THE NEW SYMBOL OF INNOVATION

Two Solid Full Door Freezer



CFD-2F
48 cu.ft., 2 section

Stainless steel interior & exterior standard!
Fully-recessed handles
Tray slide shelving system
Exterior digital temperature controls

STANDARD FEATURES:

- Capillary tube
- CFC-free R-404a Refrigerant
- 6 Epoxy-Coated Wire Shelves per Section
- Snap-In Magnetic Door Gaskets
- Tray Slide Shelving System
- 5" Casters
- Foamed-in-place Polyurethane Insulation
- Fully Coved Interior Corners
- Interior Light
- Door Locks
- Bottom-Mount Compressor & Evaporator Coil
- Hot Gas Condensate Evaporator
- Exterior Digital Temperature Control
- Self-closing Doors with Hold Open Feature
- Assembled in the USA

MATERIALS:

INTERIOR: 304 series stainless steel interior for durability and appearance.
Epoxy-coated wire shelves.

EXTERIOR: Stainless steel cabinet and doors.



DIMENSIONAL DATA:

Model No.	L	D	H	Cu.Ft.	Shelves	H/P	Volt	Amp.	NEMA	Ship Wt.
CFD-1F	29.0	32.3	82.5	23	3	1/2	115/60/1	8.6	5-20P	380
CFD-2F	54.0	32.3	82.5	48	6	3/4	115/60/1	10.0	5-20P	560
CFD-3F	81.0	32.3	82.5	72	9	1	220/60/1	7.0	6-15P	760
CFD-1R	29.0	32.3	82.5	23	3	1/3	115/60/1	8.0	5-20P	360
CFD-2R	54.0	32.3	82.5	48	6	1/2	115/60/1	8.4	5-20P	540
CFD-3R	81.0	32.3	82.5	72	9	1/2	115/60/1	9.9	5-20P	730



Refrigeration Equipment Manufacturer

Solid Door Freezer

CFD-2F

Description: Two solid full door freezer, 48 cu. ft

Features & Benefits

Stainless steel interior and exterior for greater durability, construction and appearance.

Self-contained bottom mounted refrigeration system and high humidity coated fin coil evaporator.

- Holds -10° F to 10° F as freezer

Automatic interior light.

*Exterior LED temperature display with digital controls. **Temperature setting is easy, fast and accurate.***

Micro-controller with adjustable temperature variance, automatic defrost intervals, setpoint limits, and parameter locking functions.

2.5" thick, foamed-in-place polyurethane high density insulation.

8 adjustable epoxy-coated steel wire shelves. Built-in tray slides to accommodate shelves (standard) or 18"x26" sheet pans (optional).

*5" casters standard. **Easy mobility and installation.***

Heavy-duty overall construction for high-volume, constant duty operation.

*Self-closing doors with 90° hold open feature. **Door locks standard.***

*Hot gas condensate evaporator - **no floor drain required!***

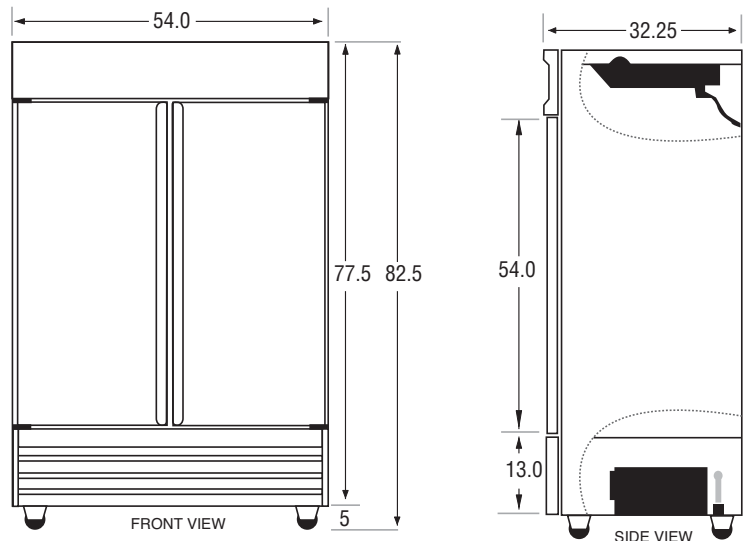
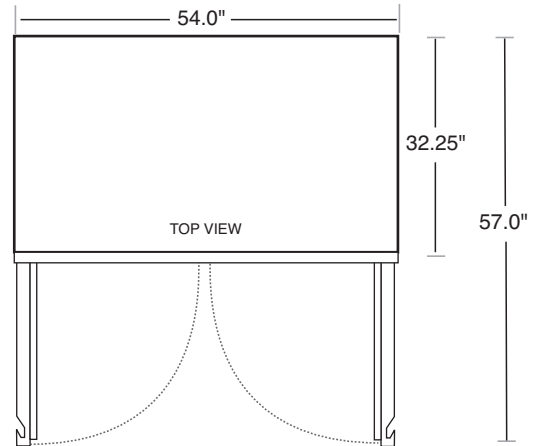

OPTIONS

- | | | |
|--------------------------|----------------------------|------------|
| <input type="checkbox"/> | Extra Interior Shelves | Qty. _____ |
| <input type="checkbox"/> | Extra Shelf Slide Brackets | Qty. _____ |
| <input type="checkbox"/> | Tray Slide Brackets | Qty. _____ |

General Information

Cubic Ft.: 48

Shelf Size: 25.5" x 21"

Doors: 2

Unit Weight: 520 lbs.

Exterior: Stainless

Ship Weight: 560 lbs.

Interior: Stainless

Technical Data

Refrigerant: R-404a

Volts: 115

Start Amps: 13.2

#Compressors: 1

Run Amps: 10.0

Cord Length: 75 in.

Horsepower: 3/4

SPECIFICATIONS SUBJECT TO CHANGE WITHOUT NOTICE