

# TABLE MODS

## Smart Table Modifications

### Size Modifications

- \_\_\_\_\_ **TA-33** .....Special Working Height
- \_\_\_\_\_ **TA-59** .....36" Wide Equipment Stand
- \_\_\_\_\_ **TA-6** ....Extra Length for Standard Tables over 12'  
(Tables Over 14' Require Field Joint TA-57)
- \_\_\_\_\_ **TA-61** .Special Sizing Charge (Larger Unit Cut Down to Smaller Size)
- \_\_\_\_\_ **TA-61A** .....Special Modification Charge
- \_\_\_\_\_ **TA-65** ...Enclosed Base Units Over 12' (Open Base Table)
- \_\_\_\_\_ **TA-66** ...Enclosed Base Units Over 12' (Sliding Door Units)
- \_\_\_\_\_ **TA-67** ...Enclosed Base Units Over 12' (Hinged Door Units)
- \_\_\_\_\_ **TA-78** ...Additional Lin. Ft. Past 12' For Table Mt. Shelf  
(For ODS, OTS, TS, DS & WS Shelving only)
- \_\_\_\_\_ **TA-105** ..Modify Enclosed Base Table with Drawers  
to 24" Width
- \_\_\_\_\_ **TA-110** .....Modify Enclosed Base Table with  
Drawers to 36" Width

### Top Modifications

- \_\_\_\_\_ **TA-1**Notch Backsplash For Roll Up Door with Pass-Thru
- \_\_\_\_\_ **TA-3** ...Stainless Steel Hat Channel & Gusset Upgrade
- \_\_\_\_\_ **TA-7** .....10" Rear Splash
- \_\_\_\_\_ **TA-8** .....Column Notch in Rear Splash (Includes Splash)
- \_\_\_\_\_ **TA-10** .....5" Partial Back Splash
- \_\_\_\_\_ **TA-12** .....Countertop Edge
- \_\_\_\_\_ **TA-22** .....Square Edge Table
- \_\_\_\_\_ **TA-28** .....Cut-Out For Cold Well
- \_\_\_\_\_ **TA-30** .....1-1/2" Side Splash
- \_\_\_\_\_ **TA-30A** .....1-1/2" Turn Up For Table Tops
- \_\_\_\_\_ **TA-31** .....5" Side Splash
- \_\_\_\_\_ **TA-32** .....10" Side Splash
- \_\_\_\_\_ **TA-34** .....Top Cut-Out
- \_\_\_\_\_ **TA-35** .....Splash Cut-Out
- \_\_\_\_\_ **TA-56** .....5" NSF Partition
- \_\_\_\_\_ **TA-56A** .....18" NSF Partition
- \_\_\_\_\_ **TA-57** ..Prepare Welded Field Joint (Welded in field by others)
- \_\_\_\_\_ **TA-57A** ....Bolted Field Joint (Bolted in field by others)
- \_\_\_\_\_ **TA-58** .....Stepdown to 24" Working Height
- \_\_\_\_\_ **TA-79** .....Flour Trough (Factory installation only)



**TA-58 Shown**

- \_\_\_\_\_ **TA-62** .....Duplex Electrical Outlet (Under Flat Top)
- \_\_\_\_\_ **TA-62A** ..Duplex Electrical Outlet (in VKS Rear Splash)
- \_\_\_\_\_ **TA-62B** .....Duplex Electrical Outlet  
(in KSS Rear Splash. Includes 2" Return)
- \_\_\_\_\_ **TA-62C** .....Duplex Outlet GFI (Specify Location)
- \_\_\_\_\_ **TA-62D** ..Doghouse Outlet Box (Includes Duplex Outlet)
- \_\_\_\_\_ **TA-64** .....Urn Trough (Factory installation only)

- \_\_\_\_\_ **TA-75** .....Mitered Edge
- \_\_\_\_\_ **TA-76** .....Paint on Sound Deadening
- \_\_\_\_\_ **TA-82** .....Scrap Chute (6" dia. opening)
- \_\_\_\_\_ **TA-84** .....Simple Pass-Thru

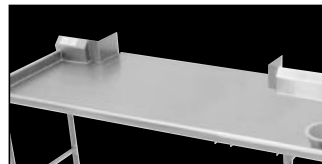

**TA-84 Shown**

- \_\_\_\_\_ **TA-87** .....Enclosed Rear Splash
- \_\_\_\_\_ **TA-91** .....Poly Retaining Clips **Includes TA-22**  
(S/S top table)
- \_\_\_\_\_ **TA-93** ....Wall Brackets (Includes 2. For 5" & 10 1/2" splash only)
- \_\_\_\_\_ **TA-96A** .....Can Opener Provision for Openers  
with Bolt-on Base (Customer to provide location)
- \_\_\_\_\_ **TA-96B** .Can Opener Surface Mount Provision with  
4" S/S Tube for Openers w/o Base (Customer to provide location)
- \_\_\_\_\_ **TA-96C**Can Opener Spacer Plate Provision for Use on Tables  
With Countertop Edge & Can Opener Base  
(Customer to provide location)
- \_\_\_\_\_ **TA-100** .....Bull Nose All Sides of Worktable
- \_\_\_\_\_ **TA-100A** .....Bull Nose All Sides of Shelf
- \_\_\_\_\_ **TA-101** .....Rear Tray Lock
- \_\_\_\_\_ **TA-106** .....Mirror HI-LITE Edge
- \_\_\_\_\_ **TA-108** .....2" Hole w/ Grommet for Cord  
(Specify Hole Location)
- \_\_\_\_\_ **TA-112** .....Hubble Outlet
- \_\_\_\_\_ **TA-113** .....Notch Top for Buyout Unit

### Base Modifications

- \_\_\_\_\_ **TA-4** .....Removable Access Panel
- \_\_\_\_\_ **TA-5** .....Curb Mounting Provision
- \_\_\_\_\_ **TA-15** .....Provision for Built In Drawer Warmer
- \_\_\_\_\_ **TA-23** .....Welded Set-Up Table/Crating
- \_\_\_\_\_ **TA-24** .....Shell Crating
- \_\_\_\_\_ **TA-27** ....Control Panel (Must add TA-34A or TA-34B)
- \_\_\_\_\_ **TA-36A** .....Sliding/Hinge Stainless Steel Doors
- \_\_\_\_\_ **TA-36B** Two 1/2 Height Stainless Steel Hinge Doors
- \_\_\_\_\_ **TA-37** .....Stainless Enclosed Base
- \_\_\_\_\_ **TA-39** .....24" Louvered Hinged Doors



**TA-39 Shown**

- \_\_\_\_\_ **TA-40** .....Remove Undershelf in Cabinet Base  
For Slide in Buyout
- \_\_\_\_\_ **TA-42** .....Interior Partition (2.5"x30")
- \_\_\_\_\_ **TA-43** .....Filler Panel (3"x30" with Flanged Feet)
- \_\_\_\_\_ **TA-44** .....K.D. Aluminum Pan Rack Slides



**Customer Service Available To Assist You 1-800-645-3166 8:30 am - 8:00 pm E.S.T.**

Email Orders To: [customer@advancetabco.com](mailto:customer@advancetabco.com). For Smart Fabrication™ Quotes, Email To: [smartfab@advancetabco.com](mailto:smartfab@advancetabco.com) or Fax To: 631-586-2933

**NEW YORK**  
Fax: (631) 242-6900

**GEORGIA**  
Fax: (770) 775-5625

**TEXAS**  
Fax: (972) 932-4795

**NEVADA**  
Fax: (775) 972-1578

# TABLE MODS

## Smart Table Modifications

(6 slides. Table min. lgth. 30")

**TA-45** . . . . .K.D. Aluminum Glass Rack Slides

(3 slides. Table min. lgth. 3 feet)

**TA-46** . . . . .Door Locks

**TA-48** . . . . .12"x12" Cut-Out in Back Panel or Undershell for Plumbing

**TA-55** . . . . .Remove Back Panel (on Enclosed Base)

**TA-70** . . . . .S/S Tubular Tray Divider (12" sections)

**TA-73** . . . . .Tubular Tray Slide w/Dropdown

(Stationary Tray Slide Available. Factory installation only)

**TA-74** . . . . .Solid Tray Slide

**TA-92** . . . . .12" Apron (in front of sink)

**TA-92A** 17" stainless Steel Apron to Cover Sink Bowls and Support Lever Drain Handles

**TA-109** . . . . .Rear Flush Finished Inset Panel



**TA-109 Shown**

**TA-116** Adjustable Enclosed Base Cabinet Mid Shelf

(Shelves over 36" in length require multiple . . . sections with center partition.)

### Sink Modifications

**TA-107** . . . . .Vacuum Breaker Holes on Tables  
(Includes Backsplash with 2" Return)

### Undershelf Modifications

**TA-9** . . . . .1-1/2" Turn-Up for Undershelves

**TA-48** . . . . .12"x12" Cut-Out in Back Panel or Undershelf for Plumbing

**TA-94** . . . . .Upgrade 16 Ga. 304 S/S Undershelf

**TA-366** . . . Reinforced Understructure For Undershelves

### Overshelf Modifications

**TA-9A** . . . 1" Turn-Up for all Table Mounted Shelves

**TA-47** . . . Shelf Mounting Bracket for Existing Table

**TA-49** . . . . .Wall Shelf 2" offset

**TA-60** . . . . .Special Sizing Charge for Shelves  
(Must Order Larger Unit to be Cut Down to Smaller Size)

**TA-62** . . . . .Duplex Electrical Outlet (Under Flat Top)

**TA-62D** Doghouse Electrical Outlet Box (Includes Duplex Outlet)

**TA-71** . . . . .Heat Lamp Mounting Provision

**TA-77** Check Minder Shelf Provision (Factory installation only)

**TA-99** 16 Ga. S/S 304 Upgrade for Wall and Over Shelves

**TA-102** . . . . .24" x 24" Extension for Microwave or Computer Shelf

(Add to OTS and ODS Shelves. See page 45)

**TA-103** . . . . .24" Wide PT Shelf (36" Min Length. Mid mount only. PT Series Shelf)

**TA-104** . . Additional Length Over 12' (Add to 18" Shelf)

(CU & CDS Shelving Only. Maximum Length is 14' as Single Piece)

### Leg Modifications

**TA-16** . . . . .Galvanized Leg with Plastic Bullet Foot

**TA-19** . . . . .Flanged Stainless Steel Bullet Feet

**TA-20** . . . . .Stainless Steel Leg with S/S Bullet Foot

**TA-21** . . . . .Stainless Steel Bullet Foot

**TA-95** . . . . .Upgrade 16 Ga. 304 S/S Legs Only

### MODIFIED EB-SS-3012

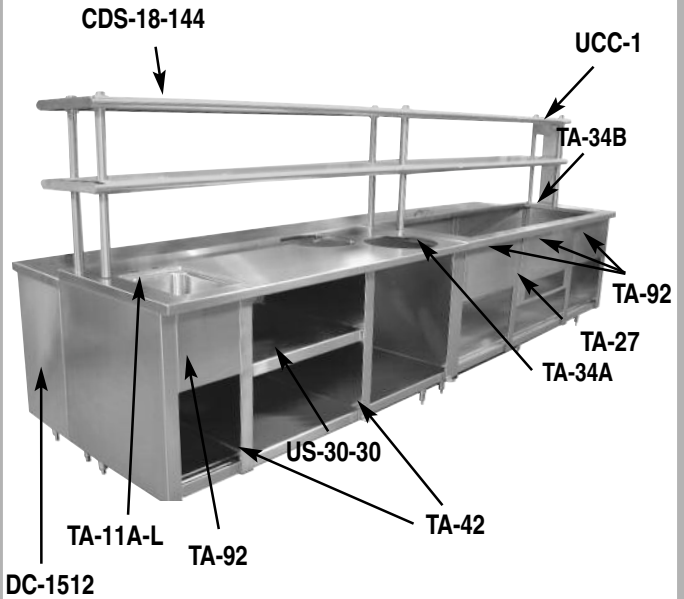

**Duplex Electrical Outlets**

TA-62 \$346 ea.  
TA-62A 208 ea.  
TA-62B 334 ea.  
TA-62C 363 ea.

**Doghouse Duplex Electrical Outlet**

TA-62D \$387 ea.

**Data Port Outlet**

TA-622 \$346 ea.



**TA-112 \$470 Hubble Outlet**



**PRT-1 \$663 Printer Shelf with Data Port & Electrical Outlet**



**TA-77 \$45 lin. ft. Check Minder Shelf Provision**



**NSF Partition 5" TA-56A \$369 18" NSF Partition TA-92 \$135 lin. ft. 12" Apron**

**Call For Installation of Buyout Equipment!**

### TOP ACCESSORIES

- \_\_\_ TA-29 Rear Splash Capping Strip
- \_\_\_ TA-41 Poly-Vance 5/8" Cutting Board
- \_\_\_ TA-521 Drop-In urn Trough 1'
- \_\_\_ TA-522 Drop-In urn Trough 2'
- \_\_\_ TA-523 Drop-In urn Trough 3'
- \_\_\_ TA-524 Drop-In urn Trough 4'
- \_\_\_ TA-812 2' Stainless Steel Cutting Surface
- \_\_\_ TA-813 3' Stainless Steel Cutting Surface
- \_\_\_ TA-814 4' Stainless Steel Cutting Surface
- \_\_\_ TA-815 5' Stainless Steel Cutting Surface
- \_\_\_ TA-816 6' Stainless Steel Cutting Surface
- \_\_\_ TA-817 7' Stainless Steel Cutting Surface

### BASE ACCESSORIES

- \_\_\_ TA-54 Removable Kick Plate
- \_\_\_ TA-63 Removable Shelving (In addition to standard shelf)

### OVERSHELF ACCESSORIES

- \_\_\_ TA-83 Spice Bins

### POTRACK ACCESSORIES

- \_\_\_ TA-86 Stainless Steel Pot Hooks
- \_\_\_ TA-89 Double Sided Plated Pot Hooks (Package of 4)
- \_\_\_ TA-89A Single Sided Plated Pot Hooks (Package of 4)
- \_\_\_ TA-98 Stainless Steel Flat Bar in lieu of Chain

### TOP ACCESSORIES

- \_\_\_ TA-84A Knife Rack for Rolled Rim Tables
- \_\_\_ TA-84B Knife Rack for Poly Top Tables
- \_\_\_ TA-84C Knife Rack for Square Edge Tables

### DRAWER ACCESSORIES

- \_\_\_ TA-13 Pad Lock Hasp (Non-catalog tables. Specify table width)
- \_\_\_ TA-90 Drawer Adapter (Non-catalog tables. Specify table width)

### LEG ACCESSORIES

- \_\_\_ TA-72 Leg to Wall Brace (Set per table)

# SMART TABLE ACCESSORIES

## Casters

(125 lbs. Load Capacity Per Caster)



TA-25

- \_\_\_ TA-25 Set of 4
  - \_\_\_ TA-25A Set of 6
- Add price to Above for:**
- \_\_\_ TA-25B Brakes on All Casters
  - \_\_\_ TA-25C Upgrade to Caster with Heavy Duty Urethane Wheels

## Heavy Duty Casters for Equipment Stands



TA-255

(1000 lbs. Distributed Weight)

- \_\_\_ TA-255 Super Heavy Duty set of 4
- \_\_\_ TA-256 Super Heavy Duty set of 6

ALL CASTERS  
SHIP VIA UPS!



## REAR SPLASH CAPPING STRIP



16 Ga. "304" Stainless Steel  
Adhesive Tape Backing

- \_\_\_ TA-29

## BUMPER GUARDS



16 ga., 304 Stainless Steel. Bracket Included

- \_\_\_ BG-48 2" x 4" x 48"
- \_\_\_ BG-60 2" x 4" x 60"

## CORNER GUARDS



16 Ga. "304" Stainless Steel  
Adhesive Tape Backing

- \_\_\_ CG-48 2" x 2" x 48"
- \_\_\_ CG-60 2" x 2" x 60"

## CHECK MINDER

**Check Minder** holds checks with ease.

Floating ball mechanism quickly grabs checks and holds them in place.

Mounts to existing wall or shelf.



Ft.	MODEL	Approx. Wt.
2'	___ CM-24	1.5 lbs.
3'	___ CM-36	2.25 lbs.
4'	___ CM-48	3 lbs.



Customer Service Available To Assist You **1-800-645-3166** 8:30 am - 8:00 pm E.S.T.

Email Orders To: [customer@advancetabco.com](mailto:customer@advancetabco.com). For Smart Fabrication™ Quotes, Email To: [smartfab@advancetabco.com](mailto:smartfab@advancetabco.com) or Fax To: 631-586-2933

**NEW YORK**  
Fax: (631) 242-6900

**GEORGIA**  
Fax: (770) 775-5625

**TEXAS**  
Fax: (972) 932-4795

**NEVADA**  
Fax: (775) 972-1578