



HIGH TEMPERATURE SINGLE RACK STRAIGHT DISHWASHER

180-S

High Temperature
Single Rack Dishwasher



FEATURES

- 60 racks / 240 covers per hour.
- Economical to operate. Uses only .82 gallons of water per cycle.
- Automatic soil purging system. Filters wash water and traps plate debris into an external tray. Tray can be easily removed for dumping contents.
- All stainless steel construction offers durable performance and years of trouble free operation.
- Built-in chemical resistant industrial 7kW (240V) heater is proven to be more durable than commercial style heaters.
- Unique spray arm system features upper and lower stainless steel wash arms with reinforced end caps.
- Auto start/stop makes operation safe and easy.
- Field convertible for a wide range of applications.
- Safety Temp feature assures 180°F sanitizing rinse every cycle.
- Single point electrical connection.
- Automatic tank fill.
- Interchangeable upper and lower arms.

AVAILABLE OPTIONS

- Exhaust Fan Time Control
- Built-in 12kW booster heater
- CMA-180 Conversion Kit Straight to Corner
- Alternative electrical available for export
- Stainless steel dishtables
- Dual power supply connections
- 3 doors open
- Slant Shelf
- Stainless Steel Scrap Trap Upgrade

CMA MODEL: 180-S



Top mounted control box is water tight and includes a rack counter, extended wash/delimer switch and easy to read temperature gauges.



External scrap tray maintains clean wash water and prevents debris from clogging the drain.

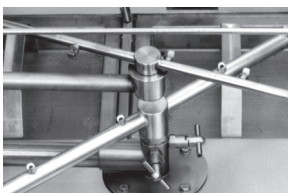

Unique pull-pin design allows wash arms to be easily removed for cleaning.

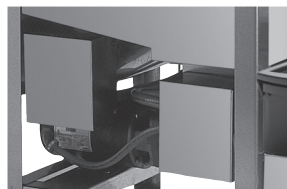

Industrial wash tank and optional booster heaters are designed for years of trouble free service.

**CMA
MIZER**
Registered Trademark





CMA-180S

High Temperature
Straight
Single Rack Dishwasher

WARNINGS:

- Plumbing connections must be made by a qualified service company who will comply with all available Federal, State, and Local Health, Plumbing and Safety codes.
- CMA recommends utilizing a water softening system to maintain water hardness measurements of 3.5 gpg (grains per gallon) or less. This will assure maximum results and optimum operation of the dishmachine.

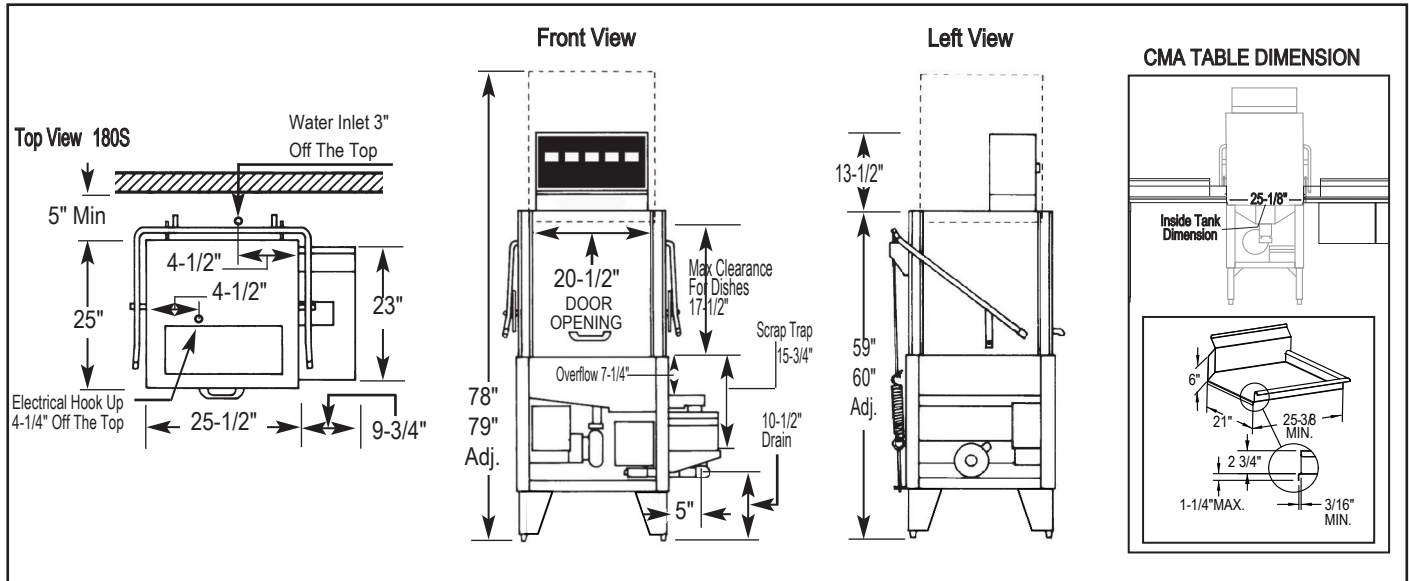

Specifications:

MODEL CMA-180S	USA	METRIC	USA	METRIC
WATER CONSUMPTION				
PER RACK	.82 GAL	(3.1 L)		
PER HOUR	49.2 GAL	(186 L)		
OPERATING CYCLE				
WASH TIME - SEC.	42	42		
RINSE TIME - SEC.	12	12		
DWELL TIME - SEC.	4	4		
TOTAL CYCLE	58	58		
OPERATING CAPACITY				
RACKS PER HOUR	60	60		
WASH TANK CAPACITY	8 GAL.	(30.3 L)		
PUMP CAPACITY	52 GPM	(197 LPM)		
WATER REQUIREMENTS				
WITHOUT BOOSTER HEATER	180°F	(82°C)		
WITH BOOSTER HEATER	120°F -140°F	(49°C - 60°C)		
WATER INLET	3/4"	(1.9cm)		
DRAIN CONNECTION	2"	(5.1cm)		
RINSE PRESSURE SET	20 ±5psi	(1.41 kg/cm²)		
OPERATING TEMPERATURE				
WASH-°F (MIN)	155°F-160°F	(68°C-71°C)		
RINSE-°F (MIN)	180°F-195°F	(82°C-90°C)		
WASH PUMP MOTOR HP			1	1
DIMENSIONS				
DEPTH			25"	(63.5cm)
WIDTH (OUTSIDE DIMENSION)			25"-1/2"	(65cm)
TOTAL HEIGHT WITH DOOR OPEN			78"-79"	(198-212cm)
STANDARD TABLE HEIGHT			34"	(86.3cm)
MAX CLEARANCE FOR DISHES			17-1/2"	(44cm)
DRAIN CONNECTION (OFF FLOOR)			11-1/2"-12-1/2"	(29-32cm)
STANDARD DISHRACK			1	1
DIMENSIONS			20" x 20"	(50.8 x 50.8cm)
ELECTRICAL RATING			VOLTS	PHASE
WITHOUT BOOSTER			208	1
			240	1
			208	3
			240	3
			480	3
WITH BOOSTER			208	1
			240	1
			208	3
			240	3
			480	3
APPROXIMATE SHIPPING WEIGHT				
STRAIGHT WITHOUT BOOSTER			338#	(151kg)
STRAIGHT WITH BOOSTER			357#	(161.9kg)
STRAIGHT-EXT WITH BOOSTER				
SHIPPING DIMENSIONS			PALLET & BOX @ 41" X 41" X 80"	

Summary Specifications: Model CMA-180S

The model CMA-180S single tank, high temperature dishwasher is designed for years of trouble free service, producing sparkling results while conserving energy, water and chemicals. This machine is available with an optional "built in" booster heater, assuring a continuous supply of 180°F hot water, and is easily field convertible for either corner or straight installation. Unique soil purging system filters wash water and plate debris into an external tray. The CMA-180S is NSF, UL, CUL approved. Constructed entirely of stainless steel.

Available Models: ■ CMA-180C Corner ■ CMA-180S Straight
 ■ CMA-180CB Corner with booster ■ CMA-180SB Straight with booster

Advisory: CMA does NOT endorse "Tankless On-Demand" water heaters for use on CMA Dishmachine products. CMA DOES endorse, and highly recommends, the standard "tank" style water heaters, sized properly to handle each particular facility with their water heating requirements.



CMA Dishmachines 12700 Knott Street Garden Grove, CA 92841 • 800-854-6417 • 714-898-8781 • Fax: 714-895-2141 • www.cmadishmachines.com

CMA reserves the right to modify specifications or discontinue models without prior notification.

© 7-2021 CMA, Inc.

an Ali Group Company



The Spirit of Excellence