

PRODUCT: QUANTITY: ITEM #:

Designed Smart

CP Version

- Units are equipped with an infinite control for each heating element and feature a heavy-duty auto-cycling pilot light.
- Units have cooling vents on all sides for proper ventilation.
- A removable aluminum splash-plate is located under each of the heating elements allowing for easy cleaning.
- CP-2A Model offers 1800W of power, separated into a 1250W and 550W burner.

CHP Version

- The element is 7 1/2" in diameter and features a flat cooking surface.
- The element sits on a heavy-duty structure which enables the support of stockpots. This special support provides the added necessary ventilation for stockpot cooking.
- Cooking surface element features a heavy-duty aluminum splash plate and is easily removed for cleaning.



Models: CHP-1A, CP-1A, CP-2A

Built Solid

Built to Last

- Models CP-1A and CP-2A are constructed of heavy-duty stainless steel, with either single or twin flat sided heating elements.
- Model CHP-1A is constructed of 20 ga. heavy-duty stainless steel with a single electrical heating element.
- Units are equipped with a cord and plug which exits from the rear right-hand corner.

Reliability backed by APW Wyott's Warranty

- All APW Wyott hot plates are backed by a 1-year parts and labor warranty.
- Certified by the following agencies:



APW Wyott Design Features

CP-1A/2A

- Lightweight, portable
- Single and twin heating element styles
- All stainless steel construction
- Each heating element is 6" in diameter
- Easy front-view pilot lights - auto-cycling
- Cord & Plug located out-of-the-way, back corner exit.
- Removable aluminum splash-plate under element

CHP-1A

- Heavy-duty single element - 1650W of power
- Heating element is 7 1/2" in diameter
- All stainless steel construction
- Infinite controls
- Heavy-duty high rise element support for large stockpots
- Auto-cycling pilot light
- Full 7 7/8" height for easier product placement on the stove
- Cord & Plug located out-of-the-way, back corner exit
- Removable aluminum splash-plate under element

See reverse side for product specifications.

PRODUCT:

QUANTITY:

ITEM #:

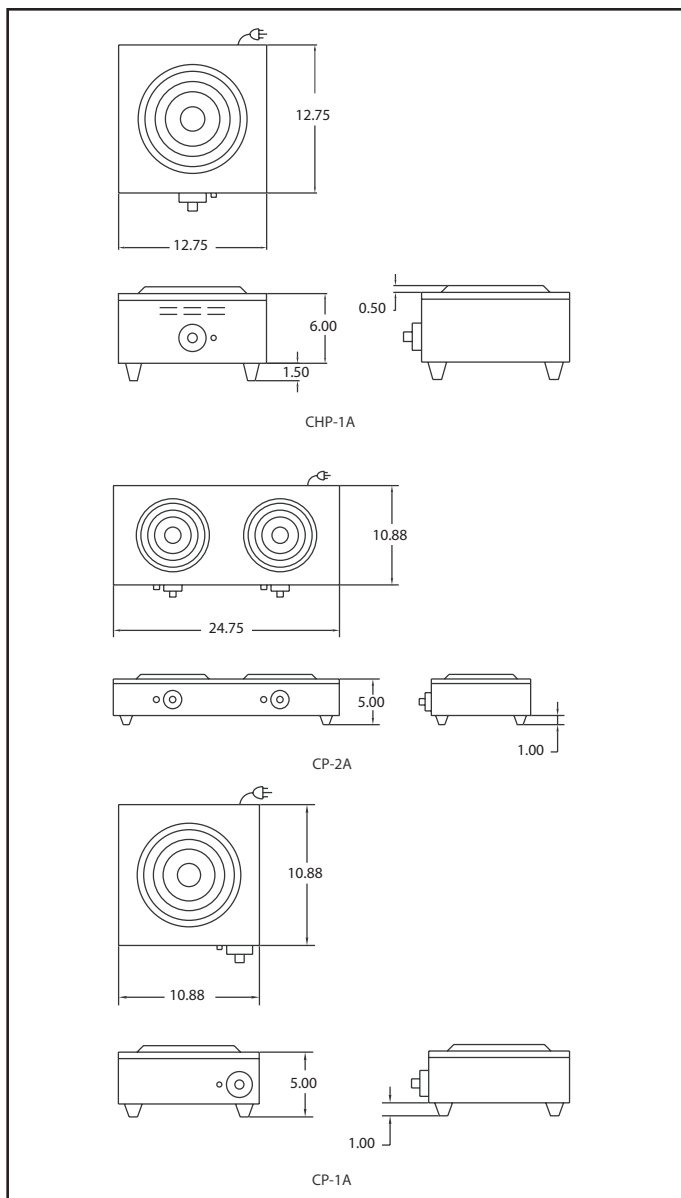

PRODUCT SPECIFICATIONS

Construction:

Heavy-Duty Stainless steel construction.
Aluminum splash plate.
One inch adjustable legs.

Electrical Information:

Each unit is equipped with a 66", three wire grounded power cord which terminates with a standard three-pronged male plug.

Electrical Specifications:

CP-1A: 120V, 1250W; 10.4 Amps

CP-2A: **First Burner:**
120V, 1250W; 13.8 Amps
Second Burner:
120V, 550W; 4.6 Amps
Total Both Burners:
120V, 1800W; 15 Amps

CHP-1A: 120V, 1650W, 13.8 Amps

Overall Dimensions:

CP-1A 5"H x 10.875"W x 10.875"D
(12.7cm x 27.6cm x 27.6cm)
Burner: 6"

CP-2A 5"H x 24.75"W x 10.875"D
(12.7cm x 62.9cm x 27.6cm)
Burner: 6" (two)

CHP-1A 7.125"H x 12.75" W x 12.75"D
(18.1cm x 32.4cm x 32.4cm)
Burner: 7½"

Shipping:

CP-1A 11 lbs (24.3 kg)

CP-2A 17 lbs (7.7 kg)

CHP-1A 14 lbs (30.8 kg)

F.O.B. Dallas, TX 75226

World Class Support

World Class Sales Support to assist you with finding the right solution to your operation's needs. Call Customer Service at 1-800-527-2100 or Fax your request to 1-214-565-0976. For more information about APW Wyott's World Class Support and High Performance Equipment, visit our website at APWwyott.com.

Most Extensive Service System in the Industry! Wyott has three levels of service support for your needs:

- Direct Service Hot Line to Service Department, call 1-800-527-2100.
- To find the Registered Service Technician in your area, call Automated Service Hot Line at 1-800-733-2203.

*APW Wyott reserves the right to modify specifications or discontinue models without incurring obligation.