



CPT67

Commercial Series Pizza Prep Table



CPT67
2/14
Item #13315



- Stainless steel exterior front, sides and top
- Anodized Aluminum interior sides and back with stainless steel interior floor
- Stainless steel exterior door with ABS interior liner
- Solid state digital controller with temperature alarms and LED display (Fahrenheit or Celsius)
- Rail utilizes a unique ducted air distribution system to distribute air evenly and maintain product temperature
- Exclusive "stepped" door design to protect door gasket
- Spring assisted self-closing doors with stay open feature
- Extruded aluminum flush mount door handle
- Field reversible doors
- Front breathing air flow design
- Provided with a full complement of polycarbonate plastic 1/3rd size pans, 4" deep, and adapter bars
- 67" x 19" x 1/2" thick white polyethylene cutting board is standard
- Enamel coated evaporator coil
- Four epoxy coated adjustable shelves are standard
- Anodized aluminum shelf supports adjustable in 1/2" increments
- Standard with 6" casters (two with brakes)
- Three year parts and labor warranty
- Five year compressor warranty
- 8 ft. cord and plug

Dimensions / Capacity

Model #	Two Section CPT67
Interior Storage Capacity (CF)(AHAM)	19.9 ft ³
Overall Width x Depth	67" x 32.24"
Height (including 6" casters)	43.45"
Depth with Cutting Board Installed	36.17"
Door Opening Width x Height	22.59" x 22.92"
Depth with Door open at 90°	57.71"
Adjustable Shelves	4
Shelf Dimensions (W x D)	24.8" x 25.61"
Pan Capacity (# of 1/3rd size x 4" deep)	9
Maximum Pan Depth	6"
Crated Shipping Weight	approximately 400 lbs
Crated Height x Width x Depth	44.25" x 68.75" x 33.75"

Electrical / Refrigeration Data

Model #	Two Section CPT67
Amperage	5.5
Energy Consumption (kwh/day) NSF	5.0
Heat Rejection (BTU/Hr.) @NSF	778
Approx. Nominal Compres. BTU/HR(HP)	2607 (1/3HP)

Hoshizaki America, Inc. reserves the right to change specifications without notice.

Item #

Project:

Qty:

*AutoCad available on KCL

CPT67 Dimensions W x D x H

2 Section - 67" x 32.24" x 43.45"*

*with 6" casters

Electrical/Refrigeration

Voltage 115/60/1

HACR Breaker
2 Section - 15.0 Amps

Electrical Connection (NEMA)
2 Section - 5-15P

Voltage Range 104-126

Ambient Temp. Range 45° to 86°F

Control Setpoint Range 28° to 45°F

*Refrigerant R-134a

Warranty

Valid in United States, Canada, Puerto Rico, and U.S. Territories. Contact factory for warranty in other countries.

- **Three Year** - Parts & Labor on entire machine.
- **Five Year** - Parts on: Compressor.

Options

- 6" Legs
- Additional epoxy shelves
- Divider bars



© HOSHIZAKI AMERICA, INC.

618 Hwy. 74 S., Peachtree City, GA 30269
TEL 800-438-6087
FAX 800-345-1325
www.hoshizaki.com



CPT67

Commercial Series Pizza Prep Table

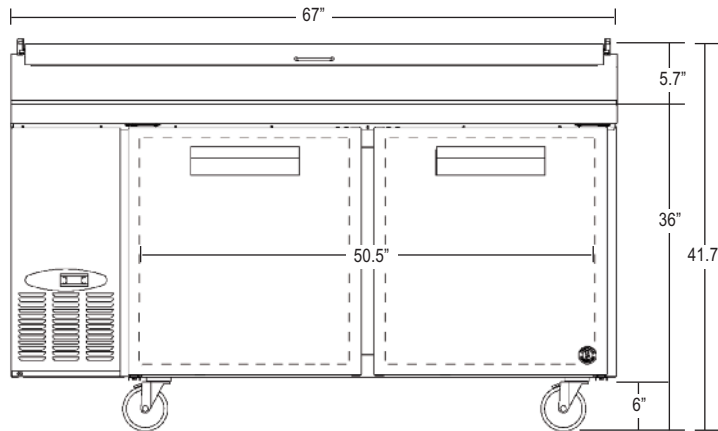

CPT67
FRONT

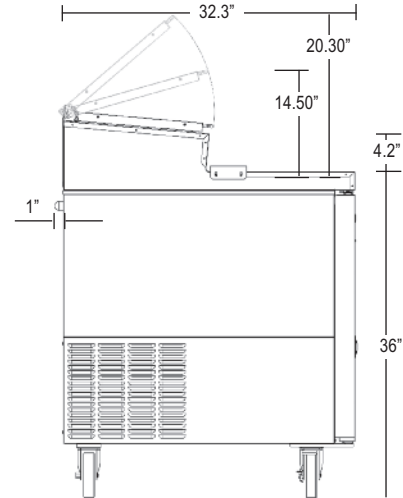

CPT67
SIDE VIEW

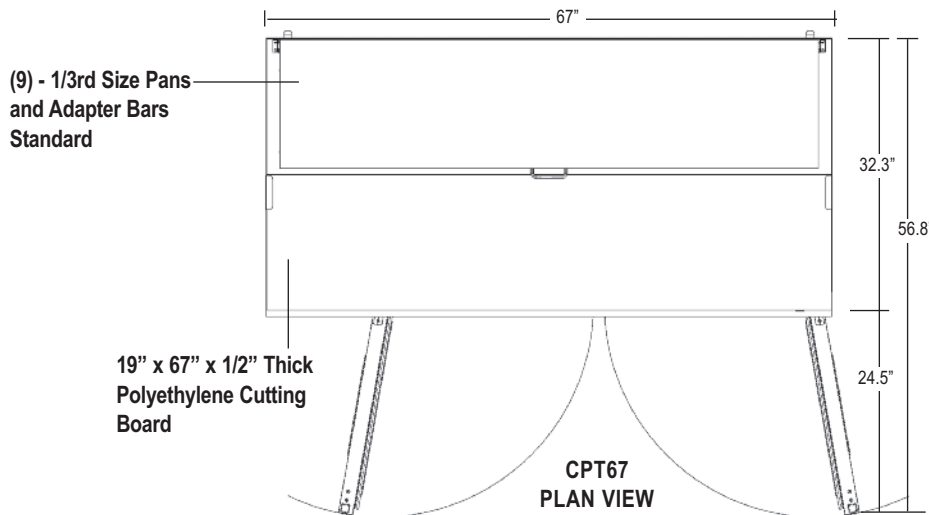

CPT67
PLAN VIEW

Cabinet Construction

The exterior cabinet top, front, and sides, are constructed of high quality stainless steel. The exterior back and bottom are constructed of coated steel. The cabinet interior back and sides are anodized aluminum with an ABS ceiling and stainless steel floor. Two heavy duty epoxy coated shelves per section are standard. Mounted on anodized aluminum pilasters the shelves are adjustable in 1/2" increments. Cabinet walls and doors are insulated with 2" of foamed in place polyurethane. 6" polyolefin, stem casters (two with brakes) are standard. The raised refrigerated rail is constructed of stainless steel interior and exterior (except back is galvanized steel). The rail is air cooled and utilizes a unique ducted air distribution system to distribute air evenly and maintain product temperature at safe levels. The rail will accommodate 1/6th, 1/3rd, 1/2 and full size pans 6" deep. Pans are located 1.5" below the front of the rail to assist in access to food product. An insulated, stainless steel, one piece hinged, lid is standard. Pizza preparation tables are supplied with full length x 19" deep x 1/2" thick N.S.F. approved polyethylene cutting boards as standard.

Door Construction

Doors are constructed of high grade stainless steel exterior with an ABS interior liner. Hoshizaki's exclusive "stepped" design protects the recessed gasket while product is removed from the cabinet. Doors are provided with a one piece, extruded aluminum, flush mount handle. Spring assisted self-closing doors are equipped with a stay open feature past 90 degrees. Snap-in magnetic door gaskets are durable and easily removed for cleaning. Field reversible door hinging is standard.

Refrigeration System

Front breathing refrigeration system allows unit to be built in to any enclosure with zero clearance at the side or rear. The high efficiency refrigeration system is self-contained with an enamel coated evaporator for extended life. Condensate removal is accomplished with an energy efficient non-electric evaporation system. A capillary tube controls the flow of environmentally friendly R-134A refrigerant through the evaporator. Refrigeration system utilizes a heated defrost element to eliminate any ice on the evaporator coil. An innovative ducted air distribution system distributes air evenly around food product in the rail. Product temperatures are maintained between 33°F and 41°F at 86° ambient room temperature to comply with N.S.F. 7. Pizza preparation tables are supplied with a full complement of N.S.F. approved polycarbonate plastic, 1/3rd size pans, 4" deep and stainless steel adapter bars. 115 volt units are equipped with an eight foot cord and NEMA rated plug (20.0 amps or less).

© HOSHIZAKI AMERICA, INC.

618 Hwy. 74 S., Peachtree City, GA 30269 • TEL 800-438-6087 • FAX 800-345-1325 • www.hoshizaki.com

A City Discount



Intertek



Intertek



ISO9001-ISO14001