



CRMF60

Commercial Series Undercounter Freezer



CRMF60
6/13
Item # 13305



- Stainless steel exterior front, sides and top
- Front breathing air flow design
- Anodized Aluminum interior sides and back with stainless steel interior floor
- Stainless steel exterior door with ABS interior liner
- Cabinet and doors are insulated with 2" of CFC free, foamed in place polyurethane
- Exclusive "stepped" door design to protect door gasket
- Spring assisted self-closing doors with stay open feature
- Extruded aluminum flush mount door handle
- Field reversible doors
- Magnetic door gasket is easily removable for cleaning
- Enamel coated evaporator coil
- Anodized aluminum shelf supports adjustable in 1/2" increments
- Standard with 4" stem casters (two with brakes)
- Three year parts and labor warranty
- Five year compressor warranty
- 8 ft. cord and plug

* CRMF60 is ENERGY STAR qualified

Dimensions / Capacity

Model #	Two Section CRMF60
Nominal Storage Capacity (CF)	17.55 ft ³
Interior Storage Capacity (CF) (AHAM)	16.6 ft ³
Overall Width x Depth	60" x 30"
Height (including 4" casters)	33.63"
Door Opening Width x Height	25.5" x 22.9"
Depth with Door open at 90°	57.5"
Adjustable Shelves	2
Shelf Dimensions (W x D)	27.3" x 15.9"
Crated Shipping Weight	268 lbs
Crated Height x Width x Depth	36.5" x 62" x 34"
Stacking Height (number of units)	4

Electrical / Refrigeration Data

Model #	Two Section CRMF60
Amperage	6.0
Energy Consumption (kwh/day) ENERGY STAR	4.86
Heat Rejection (BTU/Hr.) @NSF	821
Approx. Nominal Compres. BTU/HR(HP)	1527(1/3HP)

Hoshizaki America, Inc. reserves the right to change specifications without notice.

Item #

Project:

Qty:

*AutoCad available on KCL

CRMF Dimensions W x D x H

60" x 30" x 33.63"*

*with 4" casters

Electrical/Refrigeration

Voltage 115/60/1

HACR Breaker
15.0

Electrical Connection (NEMA)
5-15P

Voltage Range 104-126

Ambient Temp. Range 45°-100°F

Control Setpoint Range -10° to 10°F

*Refrigerant R-134a

Warranty

Valid in United States, Canada, Puerto Rico, and U.S. Territories. Contact factory for warranty in other countries.

- **Three Year** - Parts & Labor on entire machine.
- **Five Year** - Parts on: Compressor.

Options

- 2.25" Casters to meet ADA
- 6" Casters
- Additional epoxy shelves



© HOSHIZAKI AMERICA, INC.

618 Hwy. 74 S., Peachtree City, GA 30269
TEL 800-438-6087
FAX 800-345-1325
www.hoshizaki.com



CRMF60

Commercial Series Undercounter Freezer

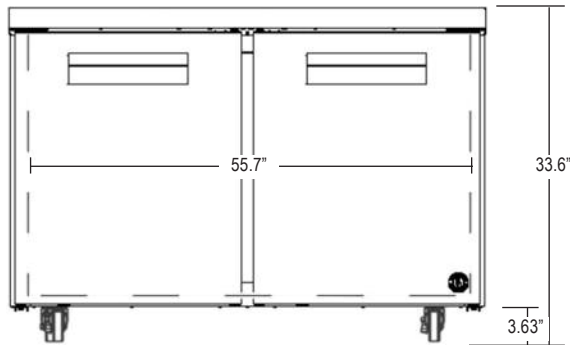

CRMF60
FRONT

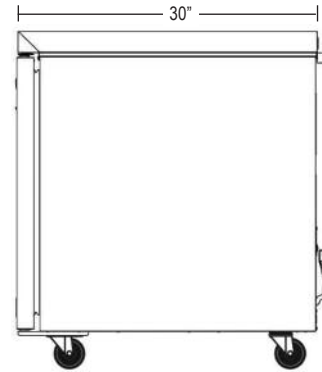

CRMF60
SIDE

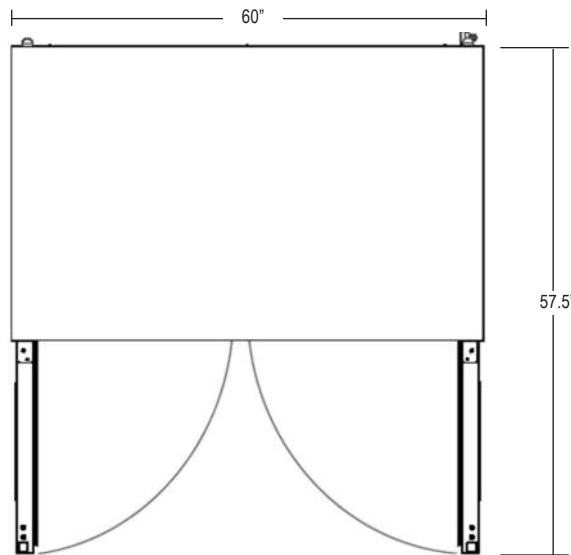

CRMF60
PLAN VIEW

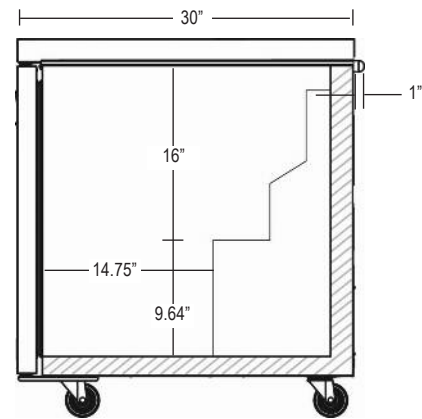

SIDE
(Cross Section)

Cabinet Construction

The exterior cabinet top, front, and sides, are constructed of high quality stainless steel. The exterior back and bottom are constructed of coated steel. The cabinet interior back, sides and ceiling are anodized aluminum with a stainless steel floor. One heavy duty epoxy coated shelf per section is standard. Mounted on anodized aluminum pilasters the shelf is adjustable in 1/2" increments. Cabinet walls and doors are insulated with 2" of environmentally friendly, CFC free, foamed in place polyurethane. Perimeter door heater prevents condensation from forming on the face of the cabinet. 4" polyolefin, stem casters (two with brakes) are standard.

Door Construction

Doors are constructed of high grade stainless steel exterior with an ABS interior liner. Hoshizaki's exclusive "stepped" design protects the gasket while product is removed from the cabinet. Doors are provided with a one piece, extruded aluminum, flush mount handle. Spring assisted self-closing doors are equipped with a stay open feature past 90 degrees. Snap-in magnetic door gaskets are durable and easily removed for cleaning. Field reversible door hinging is standard.

Refrigeration System

The high efficiency refrigeration system is self-contained with an enamel coated evaporator for extended life. Condensate removal is accomplished with an energy efficient non-electric evaporation system. A capillary tube controls the flow of environmentally friendly R-134A refrigerant through the evaporator. Unit is provided with an automatic electric defrost to remove any ice on the evaporator coil. 115 volt units are equipped with an eight foot cord and plug (20.0 amps or less).

© HOSHIZAKI AMERICA, INC.

618 Hwy. 74 S., Peachtree City, GA 30269 • TEL 800-438-6087 • FAX 800-345-1325 • www.hoshizaki.com



ISO9001-ISO 4001