



# CRMR27/48

## Commercial Series Undercounter Refrigerators

CRMR27/48  
3/13  
Item # 13286



Hoshizaki America, Inc. reserves the right to change specifications without notice.



Item #

Project:

Qty:

\*AutoCad available on KCL

### CRMR Dimensions W x D x H

1 Section - 27" x 30" x 33.63"\*\*

2 Section - 48" x 30" x 33.63"\*\*

\*\*with 4" casters

### Electrical/Refrigeration

**Voltage** 115/60/1

**HACR Breaker**  
1 & 2 Section - 15.0

**Electrical Connection (NEMA)**  
1 & 2 Section - 5-15P

**Voltage Range** 104-126

**Ambient Temp. Range** 45° -100° F

**Control Setpoint Range** 20° to 52° F

\*Refrigerant R-134a

### Warranty

Valid in United States, Canada, Puerto Rico, and U.S. Territories. Contact factory for warranty in other countries.

- **Three Year** - Parts & Labor on entire machine.
- **Five Year** - Parts on: Compressor.

### Options

- 2.25" Casters - to meet ADA
- 6" Casters
- Additional epoxy shelves
- Cylinder locks -01 (factory installed)



- Stainless steel exterior front, sides and top
- Anodized Aluminum interior sides and back with stainless steel interior floor
- Stainless steel exterior door with ABS interior liner
- Cabinet and doors are insulated with 2" of CFC free, foamed in place polyurethane
- Exclusive "stepped" door design to protect door gasket
- Spring assisted self-closing doors with stay open feature
- Extruded aluminum flush mount door handle
- Field reversible doors
- Magnetic door gasket is easily removable for cleaning
- Enamel coated evaporator coil
- Anodized aluminum shelf supports adjustable in 1/2" increments
- Standard with 4" stem casters (two with brakes)
- Three years parts and labor warranty
- Five year compressor warranty
- 8 ft. cord and plug

\* CRMR27 and CRMR48 are ENERGY STAR qualified

### Dimensions / Capacity

Model #	One Section CRMR27	Two Section CRMR48
Nominal Storage Capacity (CF)	7.2 ft <sup>3</sup>	13.66 ft <sup>3</sup>
Interior Storage Capacity (CF) (AHAM)	6.22 ft <sup>3</sup>	11.95 ft <sup>3</sup>
Overall Width x Depth	27" x 30"	48" x 30"
Height (including 4" casters)	33.63"	33.63"
Door Opening Width x Height	22.6" x 22.9"	19.5" x 22.9"
Depth with Door open at 90°	54.5"	51.5"
Adjustable Shelves	1	2
Shelf Dimensions (W x D)	22.0" x 16.0"	21.3" x 16.0"
Crated Shipping Weight	160 lbs	222 lbs
Crated Height x Width x Depth	36.5" x 31.5" x 34"	36.5" x 52.5" x 34"

### Electrical / Refrigeration Data

Model #	One Section CRMR27	Two Section CRMR48
Amperage	2.6	2.6
Energy Consumption (kwh/day) ENERGY STAR	.65	1.44
Heat Rejection (BTU/Hr.) @NSF	180	327
Approx. Nominal Compres. BTU/HR(HP)	1029(1/6HP)	1029(1/6HP)



© HOSHIZAKI AMERICA, INC.

618 Hwy. 74 S., Peachtree City, GA 30269  
TEL 800-438-6087  
FAX 800-345-1325  
www.hoshizaki.com



# CRMR27/48

## Commercial Series Undercounter Refrigerators

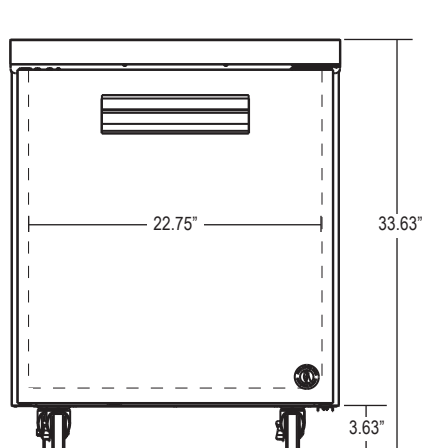

**CRMR27  
FRONT**

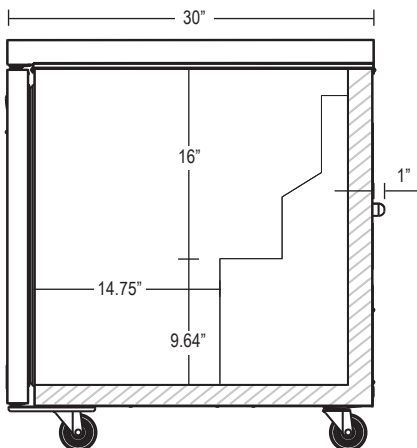

**SIDE  
(Cross Section)**

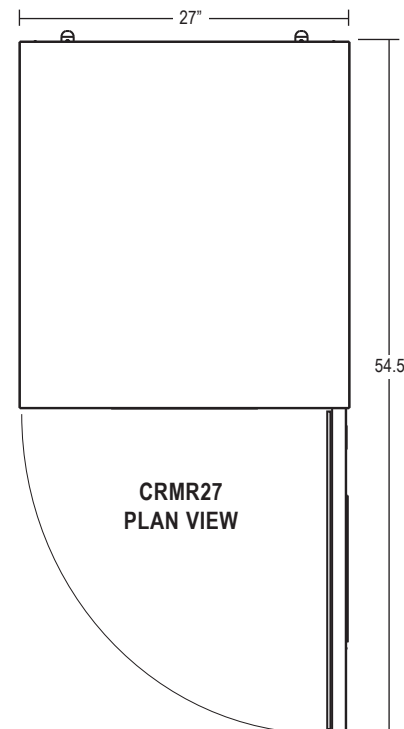

**CRMR27  
PLAN VIEW**

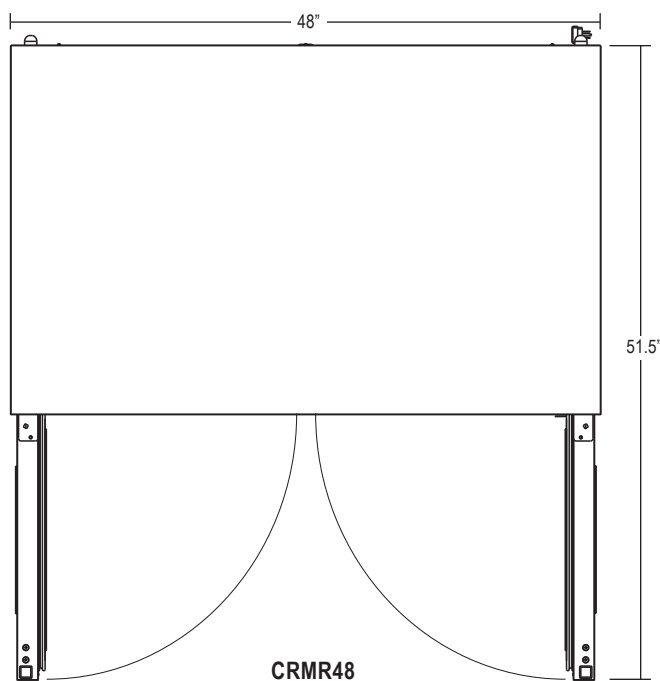

**CRMR48  
PLAN VIEW**

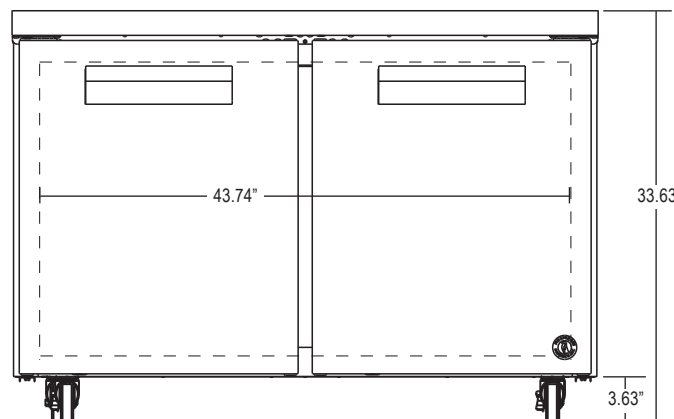

**CRMR48  
FRONT**

### Cabinet Construction

The exterior cabinet top, front, and sides, are constructed of high quality stainless steel. The exterior back and bottom are constructed of coated steel. The cabinet interior back and sides are anodized aluminum with an ABS ceiling and stainless steel floor. One heavy duty epoxy coated shelf per section is standard. Mounted on anodized aluminum pilasters the shelves are adjustable in 1/2" increments. Cabinet walls and doors are insulated with 2" of environmentally friendly, CFC free, foamed in place polyurethane. 4" polyolefin, stem casters (two with brakes) are standard.

### Door Construction

Doors are constructed of high grade stainless steel exterior with an ABS interior liner. Hoshizaki's exclusive "stepped" design protects the gasket while product is removed from the cabinet. Doors are provided with a one piece, extruded aluminum, flush mount handle. Spring assisted self-closing doors are equipped with a stay open feature past 90 degrees. Snap-in magnetic door gaskets are durable and easily removed for cleaning. Field reversible door hinging is standard.

### Refrigeration System

The high efficiency refrigeration system is self-contained with an enamel coated evaporator for extended life. Condensate removal is accomplished with an energy efficient non-electric evaporation system. A capillary tube controls the flow of environmentally friendly R-134A refrigerant through the evaporator. Refrigeration system utilizes an "off cycle" defrost to eliminate any ice on the evaporator coil. 115 volt units are equipped with an eight foot cord and plug (20.0 amps or less).

© HOSHIZAKI AMERICA, INC.

618 Hwy. 74 S., Peachtree City, GA 30269 • TEL 800-438-6087 • FAX 800-345-1325 • www.hoshizaki.com



ISO9001-ISO 4001

A City Discount