

# SUPERIOR HOODS

2018 STEEL DRIVE TUCKER GA 30084  
 TEL (770) 936-0770 FAX (770) 936-9914

DATE: \_\_\_\_\_  
 NAME: \_\_\_\_\_  
 LOCATION: \_\_\_\_\_

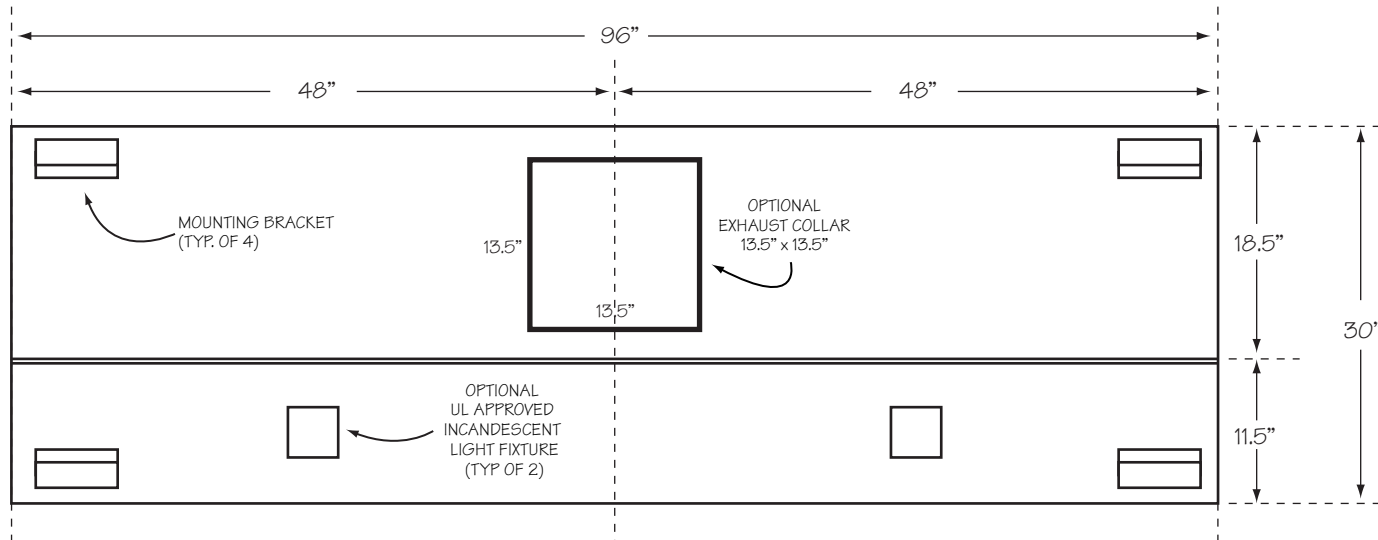

**CSS30-8**  
**STAINLESS STEEL EXHAUST HOOD**  
 N.S.F. LISTED. CONFORMS TO NFPA96  
 Hood Constructed with continuous liquid-tight weld in conformance to IMC 2012:

*"507.7.1 Type I hoods. External hood joints, seams and penetrations for Type I hoods shall be made with a continuous external liquid-tight weld or braze to the lowest outermost perimeter of the hood. Internal hood joints, seams, penetrations, filter support frames and other appendages attached inside the hood shall not be required to be welded or brazed but shall be otherwise sealed to be grease tight."*

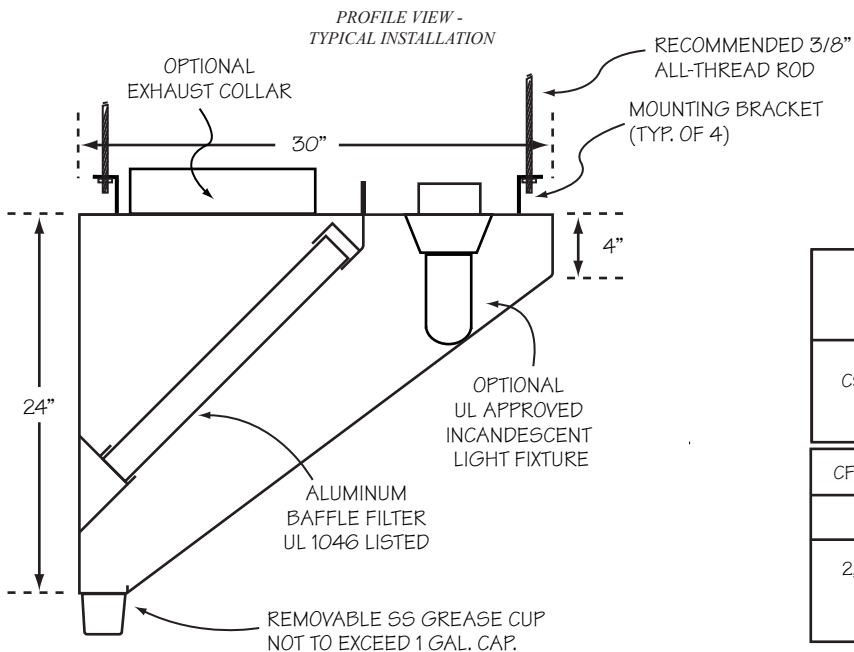

## HOOD INFORMATION

MODEL	LENGTH	WIDTH	HEIGHT	HOOD CONSTRUCTION	FILTERS				LIGHTS		
					TYPE	QTY	HEIGHT	LENGTH	QTY	TYPE	
CSS30-8	8'	30"	24"	TYPE: ALL 430 S/S GAUGE: 18 POLISH: #3	ALUMINUM BAFFLE w/HANDLES UL APPROVED	1	20"	20"	2	INCANDESCENT LIGHT FIXTURE UL APPROVED	
						3	20"	25"			
CFM REQUIREMENTS (PER HOOD)		COLLARS (PER HOOD)				ACCESSORIES					
EXHAUST	SUPPLY	EXHAUST	SUPPLY	STANDOFF	OTHER:						
2,000 @ .5 S.P.		QTY	SIZE	QTY	SIZE	<input type="checkbox"/> NONE					
		1	13.5" X 13.5"			<input type="checkbox"/> 3"					
						<input type="checkbox"/> _____					