



a Standex company

Item _____

**COUNTER TOP
SELF-SERVE NON-REFRIG.
BAKERY DISPLAY
MODEL CT-6
CT-9
CT-12**



*Generate increased impulse bakery sales with maximum product exposure.
Federal's self-serve bakery case is designed to fit on your counter
and is available in three different sizes.*

STANDARD FEATURES

- Acrylic lift-up doors for customer product access.
- Removable sliding rear doors, shelf lights, shelf supports, and shelves.
- Glass ends and rear doors.
- Adjustable white wire shelves. Shelves are adjustable up and down and can be tilted.
- Top light and shelf lights. Lights are shielded.
- All-welded steel frame construction.
- Black powder coated frame with white interior deck.
- Back light merchandising sign.
- Electronic ballast.
- Cord and plug (NEMA 5-15).
- Toggle light switch.

COUNTER TOP

SELF-SERVE NON-REFRIGERATED BAKERY DISPLAY

OPTIONAL ACCESSORIES:

- * Reflective Ends
- * Reflective Rear Doors
- * Front Swing Doors Incorporating Acrylic Lift-up Doors

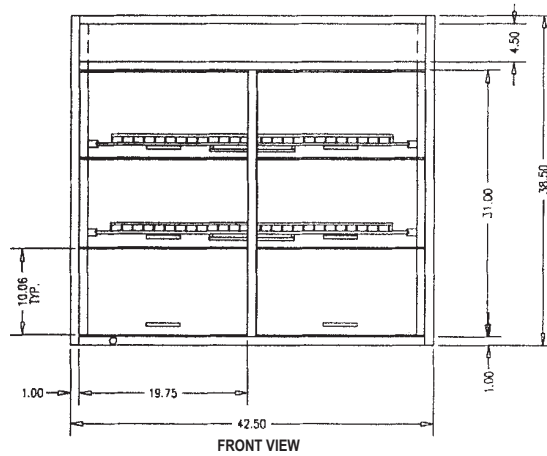
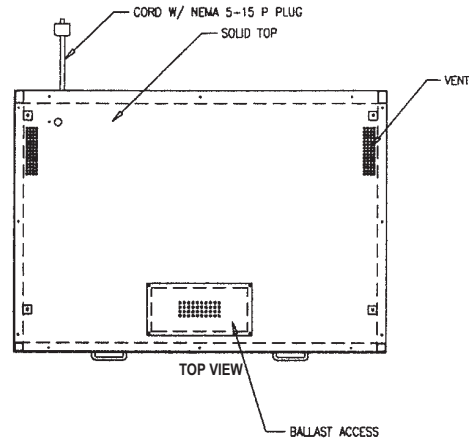
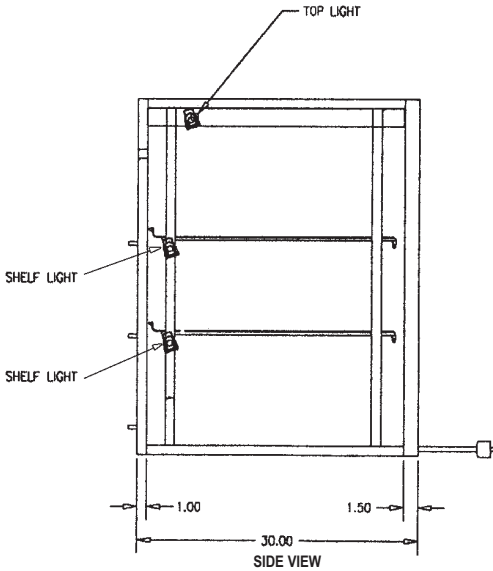

SPECIFICATIONS:

Model	Dimensions L W H	Shipping Weight (lbs)	Capacity (Bakery Pans)	Power 120/60/1
CT-6	42 1/2" x 30" x 38 1/2"	375	6 (18" x 26")	2.0 AMPS
CT-9	60 1/4" x 30" x 38 1/2"	450	9 (18" x 26")	2.0 AMPS
CT-12	80" x 30" x 38 1/2"	748	12 (18" x 26")	2.0 AMPS



- Due to continuing engineering improvements, specifications are subject to change without notice.

Look to Federal for Innovative Merchandising



a Standex company

Federal Industries
A Standex Company
215 Federal Avenue
Belleville WI 53508-0290
Phone: 800-356-4206
Fax: 608-424-3234
Email: geninfo@federalind.com
Web Site: www.federalind.com