



GTH Series GRIDLESS™ HEATED TRANSPORT CARTS AC or DC Power

CARTER-HOFFMANN
11
FOOD SERVICE EQUIPMENT
HEATED TRANSPORT CARTS



GTH12

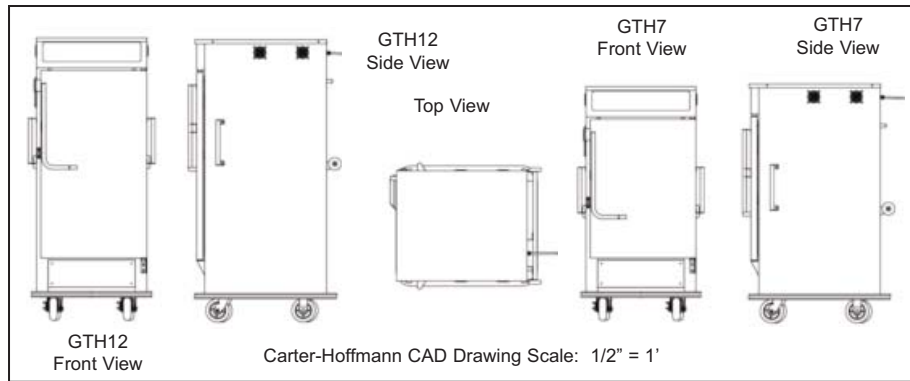

GTH12
Front View

GTH12
Side View

Top View

GTH7
Front View

GTH7
Side View

Carter-Hoffmann CAD Drawing Scale: 1/2" = 1"

Model Number	Tray/Pan Capacity*		Slide Pairs Standard	Inside Working Height		Overall Dimensions						Caster Diameter		Shipping Weight	
	18"x26"	12"x20"		in	mm	Height		Depth		Width		in	mm	lbs	kgs
						in	mm	in	mm	in	mm				
<input type="checkbox"/> GTH7	7	14	7	26 1/8	664	55 1/4	1403	37 3/8	949	32 5/8	829	6	152	575	261
<input type="checkbox"/> GTH12	12	24	12	43 5/8	1108	72 5/8	2845	37 3/8	949	32 5/8	829	6	152	640	290

* Capacity shown at 3 1/2" spacing. Tray slides adjustable on 1 3/4" increments.

CONSTRUCTION...Stainless steel cabinet construction with outer cabinet formed and welded to base. Enclosed battery compartment reinforced with 12 gauge uprights. All seams turned in to eliminate raw edges. Polished exterior.

BASE FRAME...14 gauge stainless steel extended full depth bolsters.

CASTERS...6" balloon casters. Plate mounted and bolted to base in offset wheel-ahead pattern. Delrin sleeve axle bearings and double ball bearing swivel. Zerk grease fittings. Two fixed and two swivel with brakes.

BUMPER...Non-marking red vinyl bumper set in heavy-duty 3/16" thick extruded aluminum frame with reinforced corner "cut-outs."

INSULATION...High density fiberglass, full 2" thick continuous wrap-around type in top and sides.

THERMOMETER...Digital type with remote sensing bulb.

BATTERY CHARGE...Digital battery charge level meter and % display.

DOOR...Welded double panel stainless steel pocket door. Polished exterior. Filled with 2" thick high density fiberglass insulation.

HINGES...Full length 1" tubular stainless steel hinge, mounted with 12 gauge stainless steel brackets, 16 gauge backup plates and five 5/16-18 bolts and brass bushings.

DOOR CLOSURE...Double wall pocket-style door. 1" diameter stainless steel curved door handle mounted with backup plates. Roller latches with stainless steel strike plates. "J" Hook transport latch.

HANDLES...Two 1" stainless steel tubular door handles mounted to sides of cabinet. One handle mounted to rear, with donut bumpers mounted to each end.

RACK ASSEMBLIES...Stainless steel baffles with stainless steel universal tray slides. Fully adjustable at 1-3/4" spacing. Standard spacing at 3-1/2" centers.

HEATING SYSTEM...Top mounted blower heater with side wall ducts for even heat distribution. High efficiency DC motor with cooling fans. Full range thermostat with on/off switch and AC or DC power indicator. Two 12 volt batteries for DC power operation and NEMA 5-20P plug for AC power operation.

DC POWER SYSTEM...On board batteries to power all electronics, including heating elements, blower motor, cooling fans and control board. Full

battery charge will provide 4-6 hours of operation. Robust power converter and charge controller for seamless transition from AC wall power and DC battery power and vice versa. Cart can be left to charge for as long as the user wants and will switch to a power saving mode when fully charged. Cart will operate while being charged or can be charged while the unit is cold. Battery life 3-5 years depending on number of charge cycles.

ELECTRICAL CHARACTERISTICS...Operates on 120 volts, 60 Hz, single phase, 1300 watts, 10.8 amps. Ten foot 3 wire rubber cord with 3 prong grounding plug. NEMA 5-20P. Bright LED digital temperature and battery charge. Adjustable brightness for indoor or outdoor viewing.

PERFORMANCE...Preheat to 180°F (82° C) in approximately 50 minutes. Temperature range of 160°F to 200°F (71°C to 93°C). Batteries can be charged in 4 hours or less and have a 4-6 hour run time.

ACCESSORIES/OPTIONS...

- Alternate caster sizes and types
- Four wheel brakes
- Menu card holder (5"x7" or 8.5"x11")
- 6" extended width tray slides
- Alternate electrical configuration

Specifications subject to change through product improvement & innovation.

Patent
Pending

CARTER-HOFFMANN

1551 McCormick Ave., Mundelein, IL 60060

Tel (847) 362-5500 • (800) 323-9793 • Fax (847) 367-8981

www.carter-hoffmann.com



SPECIFICATIONS

Printed in U.S.A. GTH 0417
Carter-Hoffmann is a trademark
of Carter-Hoffmann, LLC

FEATURES & BENEFITS

1551 McCormick Avenue, Mundelein, Illinois 60060
Tel. (847)362-5500 • (800)323-9793 • Fax (847)367-8981
www.carter-hoffmann.com



GTH7 & GTH12 GRIDLESS HEATED TRANSPORT CARTS

Since 1947, foodservice equipment that delivers!

OFF-THE-GRID HEATING SYSTEM... Blower heating system with side mounted interior heat ducts for fast heat up, recovery and even heat distribution throughout cabinet. Heating system can operate with AC or DC power. Two onboard batteries power cabinet for four to six hours in DC mode. Charge time of 4 hours or less. Power saving mode activated when fully charged. Heats to 200°F (93°C) in either mode.

BATTERY POWER... Two onboard batteries to power elements, fan and controls when cabinet is unplugged.



GTH12

BUILT FOR TRANSPORT... All stainless steel construction; designed to withstand the abuse of transport. Features full length tubular stainless steel hinge; "J" hook transport latch; full perimeter bumper, mounted in floating style underneath cabinet base, with non-marking red vinyl insert to protect facility walls and cabinet.

EASY ROLLING CASTERS IN OFFSET WHEEL-AHEAD PATTERN... 6" Balloon casters with leading casters placed in offset pattern so that cabinet passes over uneven surfaces such as thresholds with ease. Front casters fitted with brakes.

REMOVABLE STAINLESS STEEL TRAY SLIDE ASSEMBLIES... Baffles and slides can be removed without tools for easy cleaning. Adjustable on 1.75" centers to accommodate different pan depths.



DISPLAY... Bright LED digital temperature and battery charge display for easy viewing from a distance. Adjustable brightness for indoor or outdoor viewing.

