

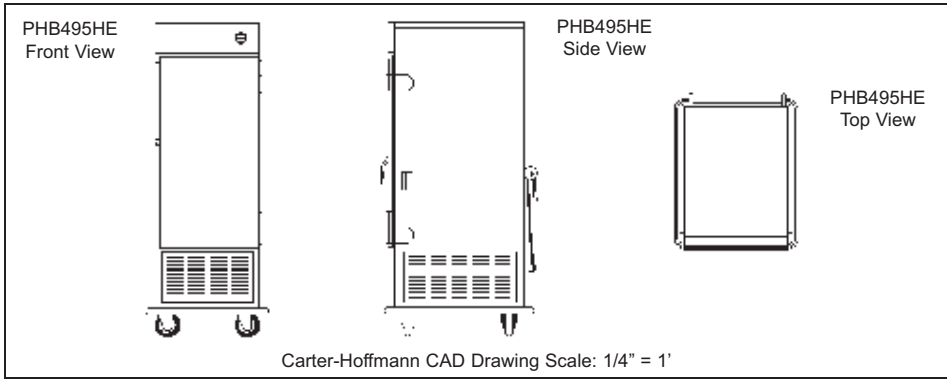

# PHB495HE AIR-SCREEN TRAYLINE REFRIGERATOR

CARTER-HOFFMANN  
11  
FOOD SERVICE EQUIPMENT  
MOBILE REFRIGERATORS



Model Number	Pan/Tray Capacity		Slide Pairs Standard	Inside Working Height		Overall Dimensions			Caster Diameter		Shipping Weight				
	14"x 18"	18"x26"		in	mm	Height in mm	Depth in mm	Width in mm	in	mm	lbs	kgs			
PHB495HE	30	15	15	45 <sup>3</sup> / <sub>4</sub>	1162	80	2032	39 <sup>7</sup> / <sub>8</sub>	1013	31 <sup>1</sup> / <sub>2</sub>	800	6	152	541	226

**CONSTRUCTION...** Completely welded cabinet construction with outer cabinet formed and welded to base. All seams turned in to eliminate raw edges.

**CABINET MATERIAL...** All stainless steel construction; 20 gauge polished exterior and 24 gauge interior.

**BASE FRAME...** 14 gauge aluminized steel full depth caster bolsters with upright supports welded to bolsters.

**CASTERS...** 6" diameter, all swivel, perform rubber tread. Sealed roller bearing swivel. Zerk grease fittings. Plate mounted and bolted to base in offset, wheel-ahead pattern. Two casters fitted with brakes.

**BUMPER...** Non-marking gray vinyl bumper set in heavy-duty 1/8" thick extruded aluminum frame with reinforced corner cutouts.

**INSULATION...** Foamed in place insulation.

**STYLING...** All stainless steel finish.

**DOOR...** All stainless steel insulated door. Positive action door hold up device keeps door open and in place for easy loading and unloading. Field reversible.

**HINGES...** Welded on, stainless steel 12 gauge butt type hinges with 3/8" fixed pin. 270 degree door swing. Field-reversible.

**PUSH HANDLE...** 1" diameter stainless steel tubular push handle bolted to rear of cabinet. Extends full width of cabinet. Equipped with donut bumpers on each end.

**LATCH...** Heavy-duty edgemount latch with magnetic catch.

**CONTROLLER...** Digital display controller set flush with control panel. Displays set point and operating temperature.

**TRAY RACK ASSEMBLIES...** Heavy-duty 18 gauge stainless steel angle slides fixed at 3" spacing. "No-tip" feature to facilitate partial pull-out of pans for easy access to contents. Partial pull-out of a pan will not "break" air screen.

**ON/OFF SWITCH...** Toggle style with guard on rear of cabinet

**REFRIGERATION SYSTEM...** Self-contained high-efficiency, evaporator coil refrigeration system. Components include 1 h.p. air cooled high torque condensing unit, horizontal air screen, 1/2 ton expansion valve, filter/dehydrator and hot gas condensate evaporator. Refrigerant charge of approx. 30 oz. CFC-free R134a.

**DEFROST...** Automatic and manual hot gas bypass defrost. Manual defrost button located on controller.

**ELECTRICAL CHARACTERISTICS...** Operates on 120 volts, 60 cycle, single phase, 7.0 running amps. Ten foot 3-wire rubber cord with 3 prong grounding plug. NEMA 5-15P.

**PERFORMANCE...** Capable of cooling cabinet to 35°F to 40°F. Approximate pull down time to 40°F - 30 minutes. Air curtain capable of maintaining 40°F internal air temperature for two hours with door open.

**ACCESSORIES/OPTIONS...**

- Rack hold down device
- Locking door latches
- Controller programmed for °C scale

# SPECIFICATIONS

Meets DOE energy regulation requirement: 10 CFR 431 Subpart C-Commercial Refrigerators, Freezers and Refrigerator-Freezers Standard

Specifications subject to change through product improvement & innovation.

**CARTER-HOFFMANN**

1551 McCormick Ave., Mundelein, IL 60060  
(847) 362-5500 • (800) 323-9793 • Fax (847) 367-8981  
[www.carter-hoffmann.com](http://www.carter-hoffmann.com)



Printed in U.S.A. G20 10819  
Carter-Hoffmann is a trademark of Carter-Hoffmann, LLC

# FEATURES & BENEFITS

## PHB495HE

### AIR SCREEN TRAYLINE REFRIGERATOR

*Since 1947, foodservice equipment that delivers!*

#### COMPLETELY WELDED TURNED-IN SEAM CONSTRUCTION...

All stainless steel construction. Adds rigidity to entire cabinet for maximum durability and reliable performance, and eliminates raw edges for easy cleaning and safety.

#### HIGH EFFICIENCY REFRIGERATION SYSTEM WITH ENVIRONMENTALLY SAFE COOLANT...

Highly efficient energy management refrigeration system provides faster pull down and recovery times. Foamed in place insulation in 2.5" thick walls.

#### PERFORMA RUBBER TREAD CASTERS WITH SEALED ROLLER BEARING...

Long lasting, easy rolling for maximum load and minimum maintenance.



#### DIGITAL READ-OUT CONTROLLER...

For fast, accurate temperature readings with no calibration.

#### 270 DEGREE DOOR SWING WITH DOOR HOLD OPEN DEVICE...

Door swings out of the way and is held securely in place for easy loading and unloading. Field-reversible hinges.

#### HEAVY-DUTY STAINLESS STEEL BASE FRAME...

12 gauge caster boosters with 14 gauge uprights to withstand heavy loads and harsh transport conditions.

#### OFFSET "WHEEL AHEAD" PATTERN...

Only one wheel can pass over uneven surfaces at a time for easy handling and steering.

#### NON-MARKING BUMPER SET IN HEAVY-DUTY 1/8" THICK EXTRUDED ALUMINUM FRAME...

Protects doorways, walls and cart from damage.

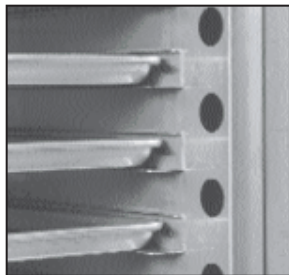

#### "NO TIP" TRAY SLIDES...

Trays cannot tip - even when pulled out half way. Enable easier access to contents of cabinet without affecting air screen.

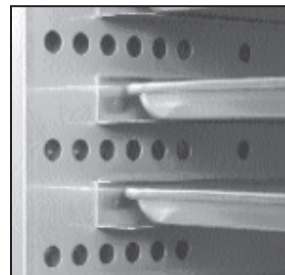

#### DUAL FAN HORIZONTAL AIR SCREEN...

Designed to maintain lower interior cabinet temperature. Pan pulled out part way will not affect air screen.

1551 McCormick Avenue, Mundelein, Illinois 60060  
Tel. (847)362-5500 • (800)323-9793 • Fax (847)367-8981  
[www.carter-hoffmann.com](http://www.carter-hoffmann.com)

