

Job: \_\_\_\_\_

Item: \_\_\_\_\_

Quantity: \_\_\_\_\_

## Mat Carts

- Labor saving mobile mat carts keep mats off of the floor for easy, efficient cleaning.
- Hooks secure perforated mats for storage and cleaning.
- Center horizontal bars hold solid mats. *(all welded unit only)*
- Open design allows use of waste container. *(K.D. model only)*
- Ideal for power washing mats on the cart.
- Lifetime Guarantee against rust and corrosion.



**99360**  
All-Welded Cart



**51087**  
Knocked Down Cart

Model No.	Size W-H-D	Wt. Cap.	Ship Lbs.
<b>All Welded</b>			
99360	41½" x 40" x 27½"	500#	40
Four 5" plate type swivel casters two (#C450), two with brake (#C455).			
<b>Knocked Down</b>			
51087	24" x 45¼" x 36"	500#	38
Four 5" plate type casters , swivel with brake (#C455).			

*This information is for general sales and engineering use only. New Age Industrial reserves the right to modify or make changes at any time without notice to materials and specifications.*

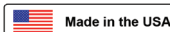

Distributed by:

Job: \_\_\_\_\_

Item: \_\_\_\_\_

Quantity: \_\_\_\_\_

## Mat Carts

**MATERIAL:**

- Framework is constructed out of 1" x 1" x .070" wall tubing.
- Mat hangers are constructed out of 5/8" diameter aluminum rod.

**CASTERS:**

- Equipped with four 5" platform type swivel casters, two with brake.

**GUARANTEES:**

- Lifetime Guarantee against rust and corrosion.
- Five-Year Guarantee against workmanship and material defects.

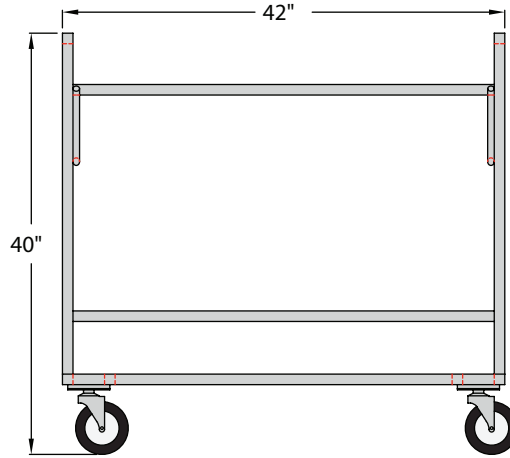

**99360**  
All-Welded Cart

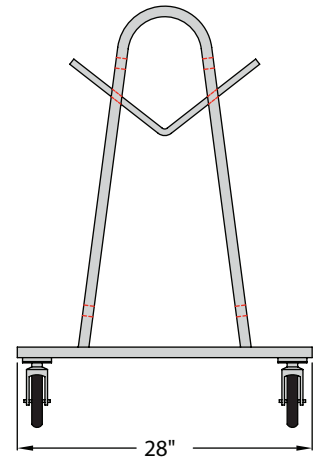

**MATERIAL:**

- Framework is constructed out of 1 1/2" x 2" x .070" wall tubing.
- Collars welded in place to accept 1 1/2" diameter pipe uprights.
- Mat hangers are constructed out of 5/8" diameter aluminum rod.

**CASTERS:**

- Equipped with four 5" platform type swivel casters with brakes.

**GUARANTEES:**

- Lifetime Guarantee against rust and corrosion.
- Five-Year Guarantee against workmanship and material defects.

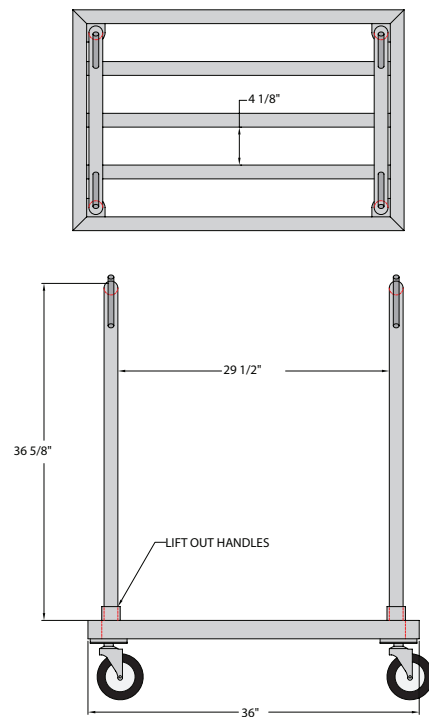

**51087**  
Knocked Down Cart

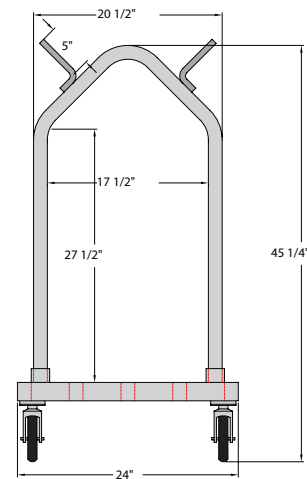

*This information is for general sales and engineering use only. New Age Industrial reserves the right to modify or make changes at any time without notice to materials and specifications.*



Distributed by: