

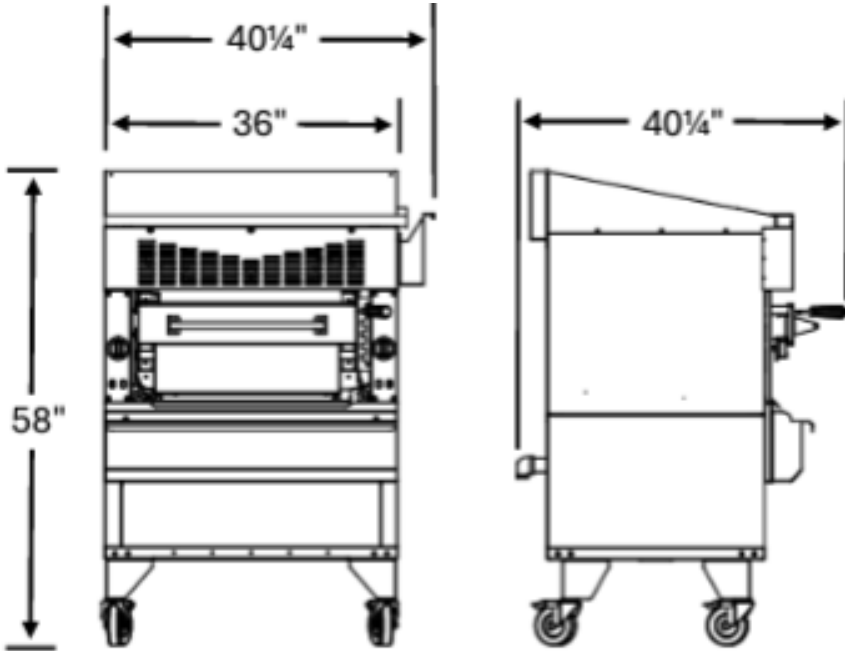

Est. 1838 • Commercial Cooking Equipment

# STEAKHOUSE GRIDDLE-BROILER



Model CCGOFB



**WARNING:** This product can expose you to certain chemicals, which are known to the State of California to cause cancer or birth defects or other reproductive harm. For more information go to: [www.P65Warnings.com](http://www.P65Warnings.com)



See website for full warranty.

## Features & Benefits

**CONSTRUCTION:** Heavy gauge stainless steel finish combined with angle iron interior construction for long life & rugged use. Heavy insulation for energy efficiency. Enclosed on three sides storage undershelf and heavy-duty casters are standard.

**BURNERS:** Extremely fast heating with three (3), heavy cast-iron radiant burners, each rated at 32,500 BTU's, combined with ceramic tiles to hold and radiate heat evenly. Intense searing heat from 900° - 1500° F to penetrate food core.

**GRIDDLE:** 35 3/4" w. x 28" d. polished steel griddle plate for searing. Splash guards on sides and rear. High-capacity side grease drawer.

**BROILER:** Roll-Out broiler grid features a spring balance lifting system with five (5), easily adjustable, height locking positions. A built-in grill stopper prevents the durable cast iron grates from inadvertently dislodging. The actual grid broiling area measures 23" x 22". Full width grease & flame deflector under the roll-out grid deck combined with a full width grease drawer under the flame deflector.

**CONTROLS:** Certified brass gas valves located to avoid harsh conditions combined with high heat resistant standing pilot system. 1" NPT rear gas manifold line, provided with a reducer elbow to 1/2"; other reducer elbow sizes available.

Model	Total BTU	Broiler Grid Size	Griddle Plate Size	Packing Size	Net Wt.	Gross Wt.
CCGOFB	97,500	22" w. x 22" d.	35 3/4" w. x 28" d.	41" w. x 44" d. x 56" h.	665 lbs.	735 lbs.