



DC SERIES

Conventional Ice Cream Storage/Dipping Cabinets

MODELS

- | | |
|--------------------------------|---------------------------------|
| <input type="checkbox"/> DC-2S | <input type="checkbox"/> DC-8D |
| <input type="checkbox"/> DC-4S | <input type="checkbox"/> DC-10D |
| <input type="checkbox"/> DC-4D | <input type="checkbox"/> DC-12D |
| <input type="checkbox"/> DC-6D | |



C-UL listing for all models except DC-12D.



FEATURES

STANDARD TEXTURED EXTERIOR



Standard white

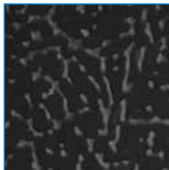

Black also available

- Anti-condensate heaters under stainless top cap
- 2 1/4" foamed-in-place "zero ODP" urethane insulation

LIDS

- Stainless steel
- Hinged with handles
- Gasket

REFRIGERATION

- Refrigerant:
 DC-12D R-404A
 All other models R-134a
- Self-contained, factory tested refrigeration system
- Force draft hermetic condensing unit (semi-hermetic unit on DC-12D with wire and tube condenser for low maintenance)
- Minimum 4" clearance required between cabinet back and wall
- Temperature range:
 10° to -10°F (-12° to -23°C)

- R-factor (insulation efficiency rating): 19.40

WARRANTY

- Standard limited two year parts and labor
- Additional three year coverage on compressor part

CONSTRUCTION

- Seamless stainless steel top
- 24 gauge painted textured galvanized steel cabinet
- Galvanized steel interior
- Equipped with leveling legs to correct for unlevel flooring situations
- Floor drain with garden hose fitting
- Galvanized steel inner liner with cold wall evaporator

OPTIONS

- Add suffix "SE" for all-stainless exterior
- Custom colors
- Lid locks
- Legs
- Casters
- Additional lids
- Load level shelves
- Dipper well



DC SERIES

CONVENTIONAL ICE CREAM STORAGE/DIPPING CABINETS

TECHNICAL SPECIFICATIONS

MODEL	DIMENSIONS (in.)			DIMENSIONS (mm)			VOLTS	AMPS	UNIT H.P.	CAN CAP. DISPLAY/STORAGE*	CAP. CU. FT.	SHIP CU. FT.	SHIP WT. LB/KG
	L	D	H	L	D	H							
DC-2S	31 ⁷ / ₈	21 ¹ / ₈	34 ¹ / ₈	810	537	867	115	5.7	1/4	3/1	5.2	19.0	195/89
DC-4S	54	21 ¹ / ₈	34 ¹ / ₈	1372	537	867	115	5.7	1/4	6/4	11.0	36.0	280/127
DC-4D	30 ⁵ / ₈	30 ¹ / ₈	34 ¹ / ₈	778	765	867	115	5.7	1/4	5/2	7.6	27.0	220/100
DC-6D	43	30 ¹ / ₈	34 ¹ / ₈	1092	765	867	115	5.7	1/4	8/5	12.5	39.0	275/125
DC-8D	54	30 ¹ / ₈	34 ¹ / ₈	1372	765	867	115	7.3	1/3	11/8	17.3	47.0	365/164
DC-10D	66 ⁵ / ₈	30 ¹ / ₈	34 ¹ / ₈	1692	765	867	115	7.3	1/3	14/11	22.0	59.0	430/195
DC-12D	84 ⁵ / ₈	30 ¹ / ₈	34 ¹ / ₈	2149	765	867	115	7.5	1/3**	18/15	29.1	71.0	490/223

*Capacity in 3 gal. cans **Semi-hermetic compressor

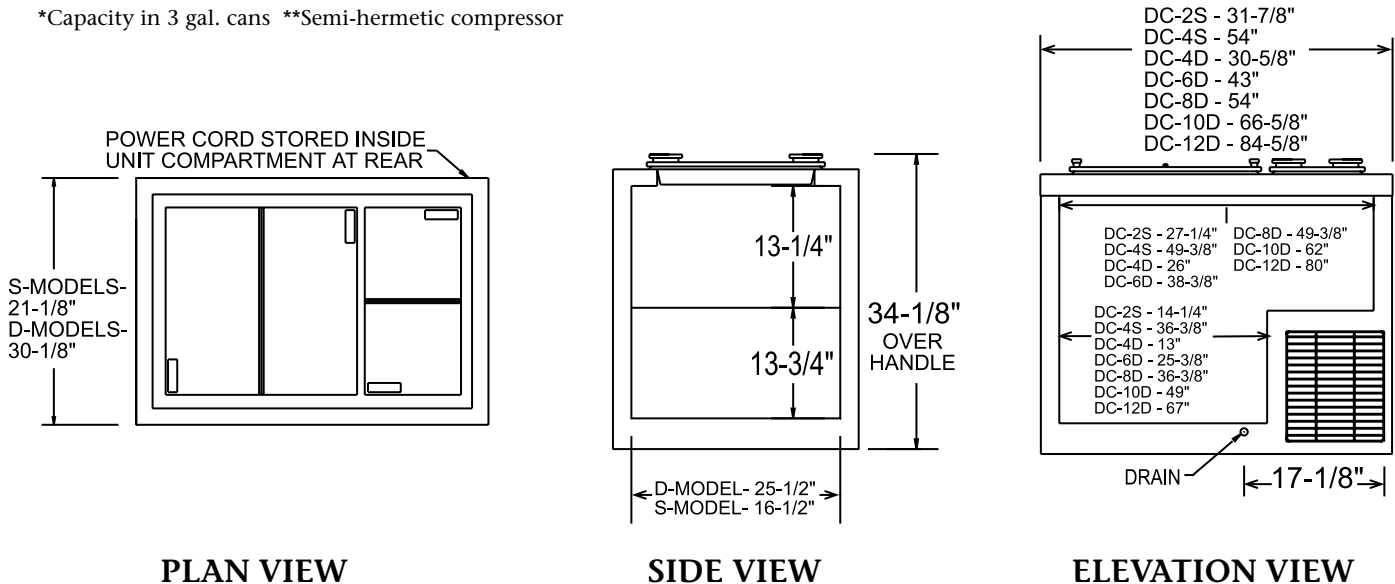

LISTINGS



C-UL listing for all models except DC-12D.

HOOKUP

Via plug in, 9 foot long, flexible 3 wire 14/3 cord with molded plug. Ten amp 115V service is recommended.



BID SPECIFICATIONS

Item no. DC-_____
Provide _____ () Conventional Ice Cream Storage/Dipping Cabinet(s), Master-Bilt model DC-_____.

Cabinet will feature textured finish on exterior with galvanized steel interior. Cabinet to have flip lids, seamless stainless steel top, 24 gauge steel walls, galvanized steel inner liner with cold wall evapora-

tor, anti-condensate heaters under stainless steel top, 2 1/4" foamed-in-place "zero ODP" urethane insulation and baked-on polyester enamel finish. Standard leveling legs provided to correct for unlevel flooring situations.

The refrigeration system will be self-contained. DC-12D will contain R-404A refrigerant and all other models will contain

R-134a. The temperature range will be 10° to -10°F (-12° to -23°C).

Cabinet to have standard limited two year parts and labor with additional three year coverage on compressor part.

Cabinet to be UL, C-UL (on all except DC-12D) and NSF listed.

NOTE: Cabinet designed for optimum performance in air-conditioned area at 75°F ambient and 55% relative humidity. All specifications subject to change without notice.



908 Highway 15 North • New Albany, MS 38652
PHONE: 800-647-1284 or 662-534-9061 • FAX: 800-232-3966 or 662-534-6049 • www.master-bilt.com

