



**Conventional
Ice Cream
Storage/Dipping
Cabinets**

MODELS

- DC-2S
- DC-4S
- DC-4D
- DC-6D
- DC-8D
- DC-10D
- DC-12D

OPTIONS

- Add suffix **"SE"** for all stainless exterior
- Custom colors

ACCESSORIES

- Lid locks
- Casters
- Load level shelves
- Legs
- Additional lids

FEATURES

CONSTRUCTION

- Seamless stainless steel top
- 24 gauge white painted galvanized steel cabinet
- Equipped with leveling legs to correct for unlevel flooring situations
- Floor drain with garden hose fitting
- Galvanized steel inner liner with cold wall evaporator
- Anti-condensate heaters under stainless top cap
- 2 1/4" foamed-in-place "low ODP" urethane insulation

FINISH

- Baked-on white polyester enamel exterior finish with galvanized steel interior

LIDS

- Stainless steel
- Hinged with handles
- Gasket

REFRIGERATION

- Refrigerant:
DC-12DR-404A
All other modelsR-134a
- Self-contained, factory tested refrigeration system

- Force draft hermetic condensing unit (semi-hermetic unit on DC-12D with wire and tube condenser for low maintenance)
- Temperature range: 10° to -10°F (-12° to -23°C)
- R-factor (insulation efficiency rating): 19.40

WARRANTY

- Standard limited four year extended compressor and one year limited parts and labor

TECHNICAL SPECIFICATIONS

| MODEL | DIMENSIONS (in inches) | | | DIMENSIONS (in millimeters) | | | VOLTS | AMPS | UNIT H.P. | CAN CAP. DISPLAY/ STORAGE* | CAP. CU. FT. | SHIP CU. FT. | SHIP WT. LB/KG |
|--------|--------------------------------|--------------------------------|--------------------------------|--------------------------------|-----|-----|-------|------|--------------|----------------------------------|-----------------|-----------------|----------------------|
| | L | D | H | L | D | H | | | | | | | |
| DC-2S | 31 ⁷ / ₈ | 21 ¹ / ₈ | 34 ¹ / ₈ | 810 | 537 | 867 | 115 | 5.7 | 1/4 | 2/1 | 5.2 | 19.0 | 195/89 |
| DC-4S | 54 | 21 ¹ / ₈ | 34 ¹ / ₈ | 1372 | 537 | 867 | 115 | 5.7 | 1/4 | 5/4 | 11.0 | 36.0 | 280/127 |
| DC-4D | 30 ⁵ / ₈ | 30 ¹ / ₈ | 34 ¹ / ₈ | 778 | 765 | 867 | 115 | 5.7 | 1/4 | 5/2 | 7.6 | 27.0 | 220/100 |
| DC-6D | 43 | 30 ¹ / ₈ | 34 ¹ / ₈ | 1092 | 765 | 867 | 115 | 5.7 | 1/4 | 8/5 | 12.5 | 39.0 | 275/125 |
| DC-8D | 54 | 30 ¹ / ₈ | 34 ¹ / ₈ | 1372 | 765 | 867 | 115 | 7.3 | 1/3 | 11/8 | 17.3 | 47.0 | 365/164 |
| DC-10D | 66 ⁵ / ₈ | 30 ¹ / ₈ | 34 ¹ / ₈ | 1692 | 765 | 867 | 115 | 7.3 | 1/3 | 14/11 | 22.0 | 59.0 | 430/195 |
| DC-12D | 84 ⁵ / ₈ | 30 ¹ / ₈ | 34 ¹ / ₈ | 2149 | 765 | 867 | 115 | 7.5 | 1/3** | 18/15 | 29.1 | 71.0 | 490/223 |

*Capacity in 3 gal. cans **Semi-hermetic compressor

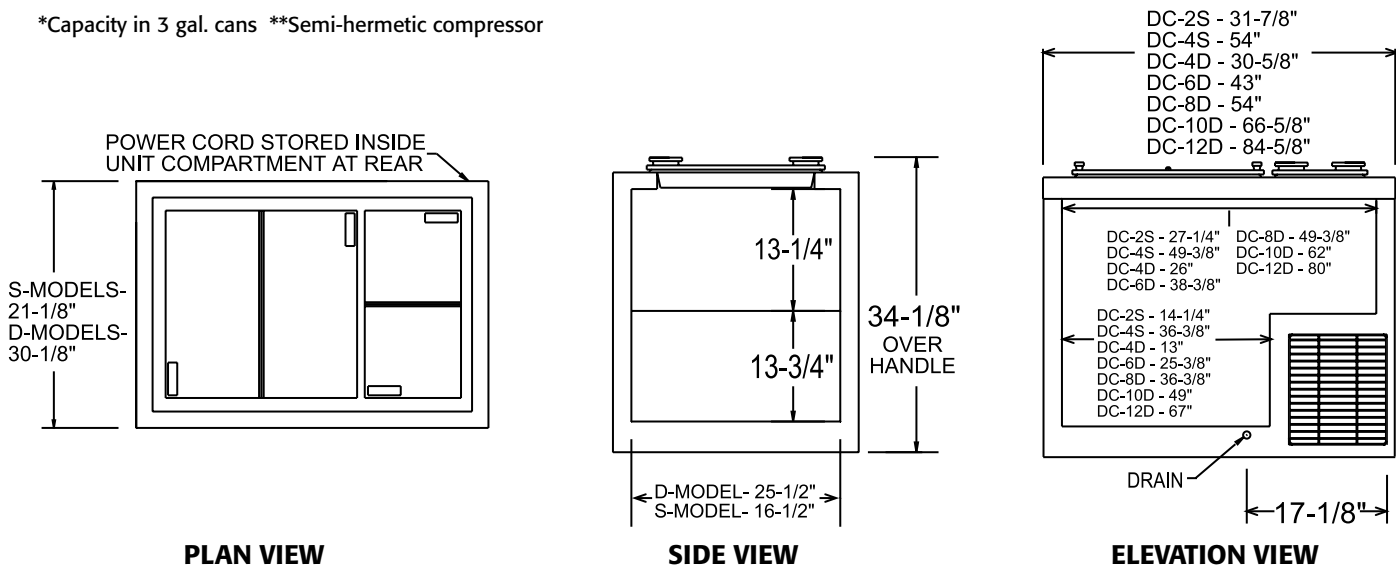

LISTINGS



C-UL listing for all models except DC-12D.

HOOKUP

Via plug in, 9 foot long, flexible 3 wire 14/3 cord with molded plug. Ten amp 115V service is recommended.

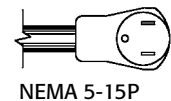

NEMA 5-15P

BID SPECIFICATIONS

Item no. DC-_____
Provide _____ () Conventional Ice Cream Storage/Dipping Cabinet(s), Master-Bilt model DC-_____.

Cabinet to have flip lids, seamless stainless steel top, 24 gauge steel walls, galvanized steel inner liner with cold wall evaporator, anti-condensate heaters under stainless

steel top, 2¹/₄" foamed-in-place "low ODP" urethane insulation and baked-on polyester enamel finish. Standard leveling legs provided to correct for unlevel flooring situations.

The refrigeration system will be self-contained. DC-12D will contain R-404A refrigerant and all other models will contain R-134a. The temperature range will be 10° to -10°F (-12° to -23°C).

Cabinet to have standard limited four year extended compressor warranty and one year limited parts and labor warranty.

Cabinet to be UL, C-UL (on all except DC-12D) and NSF listed.

NOTE: Cabinet designed for optimum performance in air-conditioned area at 75°F ambient and 55% R.H. All specifications subject to change without notice.