

DCM-500B_H

SANITARY CUBELET ICE MACHINE/DISPENSER

Item # _____

Project: _____

Qty: _____

*AutoCad available on KCL

DCM-500B_H

9/13

Item # 13226

DIMENSIONS

W x D x H

DCM-500B_H

26 x 22^{1/2} x 40

SD-450

26^{1/4} x 22 x 32^{1/2}

SD-500

25^{9/10} x 22 x 32^{3/4}

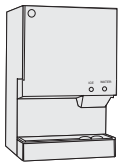

DCM-500
Countertop

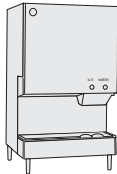

DCM-500
Countertop
with optional
6" legs

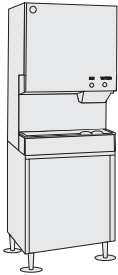

DCM-500
Floor Model
with optional
stand

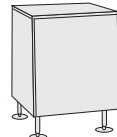

SD-450
optional
stand

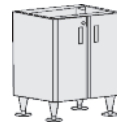

SD-500
optional
stand



DCM-500BAH

Air-Cooled
Shown on an optional
SD-500 Stand

DCM-500BWH

Water-Cooled

DCM-500B_H

- CleanCycle12®. Every 12 hours, unit performs 15 minute purge to rid itself of impurities
- Corrosion resistant stainless steel exterior
- Up to 618 lbs. of ice production per 24 hours, with 40 lbs. built-in storage
- Easy to chew, cubelet ice
- Self contained design reducing opportunities for cross contamination
- Dispenses ice and water
- Protected by H-GUARD Plus Antimicrobial Agent 



SD-450 Stand / SD-500 Stand

- Heavy duty stand for floor model icemaker/dispenser
- Corrosion resistant stainless steel exterior
- Easy cleaning with attractive appearance
- Locking doors standard on SD-500

Warranty

Valid in United States, Canada, Puerto Rico, & U.S. Territories. Contact factory for warranty in other countries.

Three Year - Parts & Labor on entire machine. (Serial numbers Vxxxxxj and after.)

Five Year - Parts on: Compressor, air-cooled condenser.



ISO9001-15014:2015

© HOSHIZAKI AMERICA, INC.

618 Hwy. 74 S., Peachtree City, GA 30269

TEL 1-800-438-6087

FAX 1-800-345-1325

www.hoshizaki.com



H

DIMENSIONS W x D x H

DCM-500B_H	26 x 22 ^{1/2} x 40
SD-450	26 ^{1/4} x 22 x 32 ^{1/2}
SD-500	25 ^{9/10} x 22 x 32 ^{3/4}

DCM-500B_H SANITARY CUBELET ICE MACHINE/DISPENSER

- Hands-free ice machine/dispenser
- Optional stand
- Optional stand with locking doors

AIR-COOLED

Water Temp ° F.	50°	70°	90°	
Air Temp ° F.	70°	618	590	561
	80°	534	509	484
	90°	461	450	418

WATER-COOLED

Water Temp ° F.	50°	70°	90°	
Air Temp ° F.	70°	567	549	539
	80°	529	519	509
	90°	500	495	481

UTILITY CONSUMPTION

Model Number	KWH per 100 LBS.		Gal. Per 100 LBS.	
	90/70	70/50	90/70	70/50
DCM-500BAH	5.62	4.02	12.0	12.0
DCM-500BWH	4.7	4.1	12.0	12.0

SPECIFICATIONS

Model Number	Condenser	Amperage	Min. Circuit Ampacity	Shipping Weight
DCM-500BAH	Air-Cooled	12.9	20	276 lbs.
DCM-500BWH	Water-Cooled	11.5	20	269 lbs.
SD-450	N/A	N/A	N/A	110 lbs.
SD-500	N/A	N/A	N/A	98 lbs.

*CUBELET DIMENSIONS

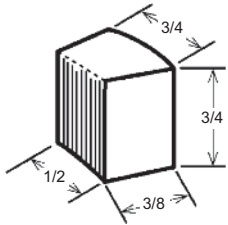

*approximate size in inches, image not to scale

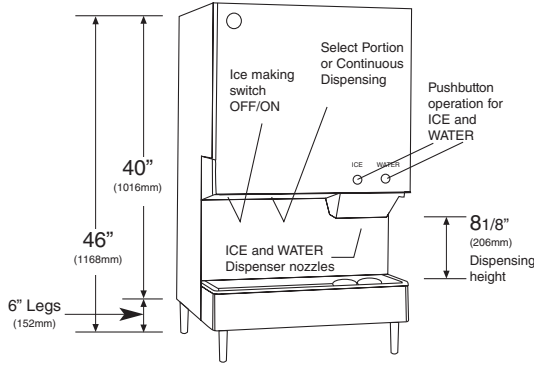

40 lb. Capacity Built-in Bin

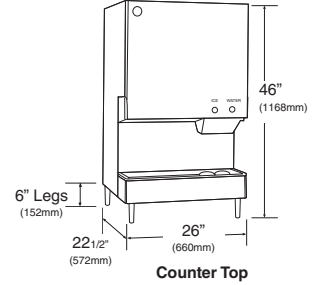

Counter Top

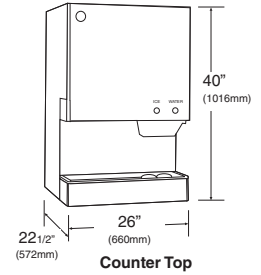

Counter Top

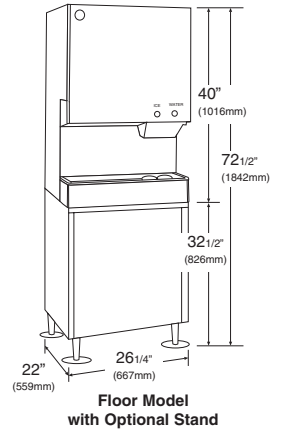
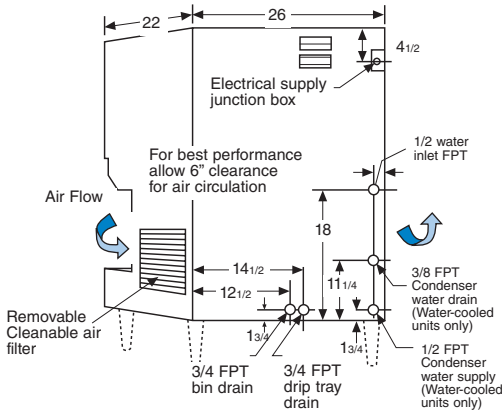

Floor Model with Optional Stand

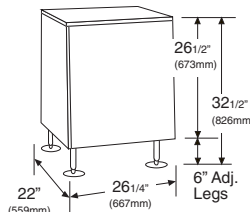

SD-450

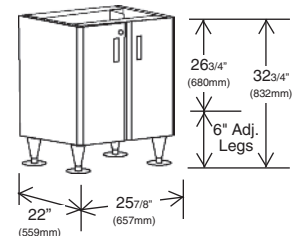

SD-500

ELECTRICAL & PLUMBING/DCM-500B_H

- 115V/60/1
- 20 amp Max Fuse Size
- 1/2" FPT Water Inlet
- 3/4" FPT x2 Drain



ISO 9001 • ISO 14001

© HOSHIZAKI AMERICA, INC.

618 Hwy. 74 S., Peachtree City, GA 30269

OPERATING LIMITS

• Ambient Temp Range	45 - 100°F
• Water Temp Range	45 - 90°F
• Water Pressure	10 - 113psig
• Voltage Range	104 - 127V

SERVICE

- Panels easily removed and all components accessible for service.
- Removable/cleanable air filter. (Air-cooled model only)

TEL 1-800-428-6087

FAX 1-800-345-1325

www.hoshizaki.com

Printed in U.S.A.

A City Discount

