

# MIB MASTER-BILT<sup>®</sup>

Refrigeration Solutions

## DD/DD-CG/DD-L SERIES



DD-46

DD-46CG

DD-46L



### Deluxe Ice Cream Dipping/Display Merchandisers

#### STANDARD MODELS

- DD-26
- DD-46
- DD-66
- DD-88

#### CURVED GLASS MODELS

- DD-26CG
- DD-46CG
- DD-66CG
- DD-88CG

#### LOW GLASS MODELS

- DD-26L
- DD-46L
- DD-66L
- DD-88L

#### OPTIONS

- Custom colors
- Removable can holders with white overnight can covers
- Dipper well
- Removable frost shields
- Leg kit
- Casters
- Lid locking kit (less locks)
- Flavor identification tabs
- Ice cream pan rack assembly (pans not included)

### FEATURES

#### CONSTRUCTION

- Attractive, contemporary design
- Equipped with leveling legs to correct for unlevel flooring situations
- Rear air intake and discharge eliminates front grille and allows full front of cabinet for graphics
- Independent on/off compressor and light switch
- Stainless steel top and attached superstructure
- 24 gauge white painted galvanized steel interior and exterior
- Tempered plate glass viewing window
- Drain with garden hose connector for ease of cleaning
- Brilliant, interior fluorescent lighting
- Stainless steel serving deck
- Top and side lid wiper gaskets

- Heavy-duty epoxy-coated wire can support racks
- 9 ft. long cord with molded plug
- 2 1/4" foamed-in-place "low ODP" urethane insulation
- Number and length of interior light fixtures:
  - DD-26/CG/L ..... (1) 18"
  - DD-46/CG/L ..... (1) 36"
  - DD-66/L ..... (1) 18", (1) 36"
  - DD-66CG ..... (2) 18"
  - DD-88/CG/L ..... (2) 36"

#### FINISH

- Sparkling white enamel interior and exterior

#### LIDS

- Hinged, high-tensile, transparent acrylic dipping compartment lids with full length handle

#### REFRIGERATION

- Cold wall evaporator
- Low maintenance bare tube condenser coil on all models except DD-26/CG/L
- Refrigerant:
  - DD-26/26CG/26L/, DD-46/46CG/46L ..... R-134a
  - DD-66/66CG/66L, DD-88/88CG/88L ..... R-404A
- Temperature range: 5° to -5°F (-15° to -21°C)
- R-factor (insulation efficiency rating): 19.40

#### WARRANTY

- Standard limited four year extended compressor and one year limited parts and labor

### TECHNICAL SPECIFICATIONS

MODEL	DIMENSIONS (in inches)			DIMENSIONS (in millimeters)			VOLTS	AMPS	UNIT H.P.	CAN CAP** DISPLAY/ STORAGE	CAPACITY CU. FT.†	SHIP CU. FT.	SHIP WT. LB/KG
	L	D	H	L	D	H							
DD-26/26CG/26L	26 <sup>1</sup> / <sub>2</sub>	27 <sup>3</sup> / <sub>4</sub>	*	673	705	*	115	7.4	1/3	4/0	3.5	38.0	240/109
DD-46/46CG/46L	47 <sup>3</sup> / <sub>4</sub>	27 <sup>3</sup> / <sub>4</sub>	*	1213	705	*	115	7.5	1/2	8/4	9.6	54.0	370/168
DD-66/66CG/66L	69 <sup>1</sup> / <sub>4</sub>	27 <sup>3</sup> / <sub>4</sub>	*	1759	705	*	115	9.7	1/2	12/8	16.0	76.0	495/225
DD-88/88CG/88L	90 <sup>3</sup> / <sub>4</sub>	27 <sup>3</sup> / <sub>4</sub>	*	2305	705	*	115	11.5	3/4	16/12	22.5	97.0	600/273

\*Height of standard and low glass models: 50" (1270mm), curved glass models: 52" (1321mm). \*\*Capacities in 9<sup>1</sup>/<sub>2</sub>" diameter, 3 gallon cans.

†Measured to the load line level.

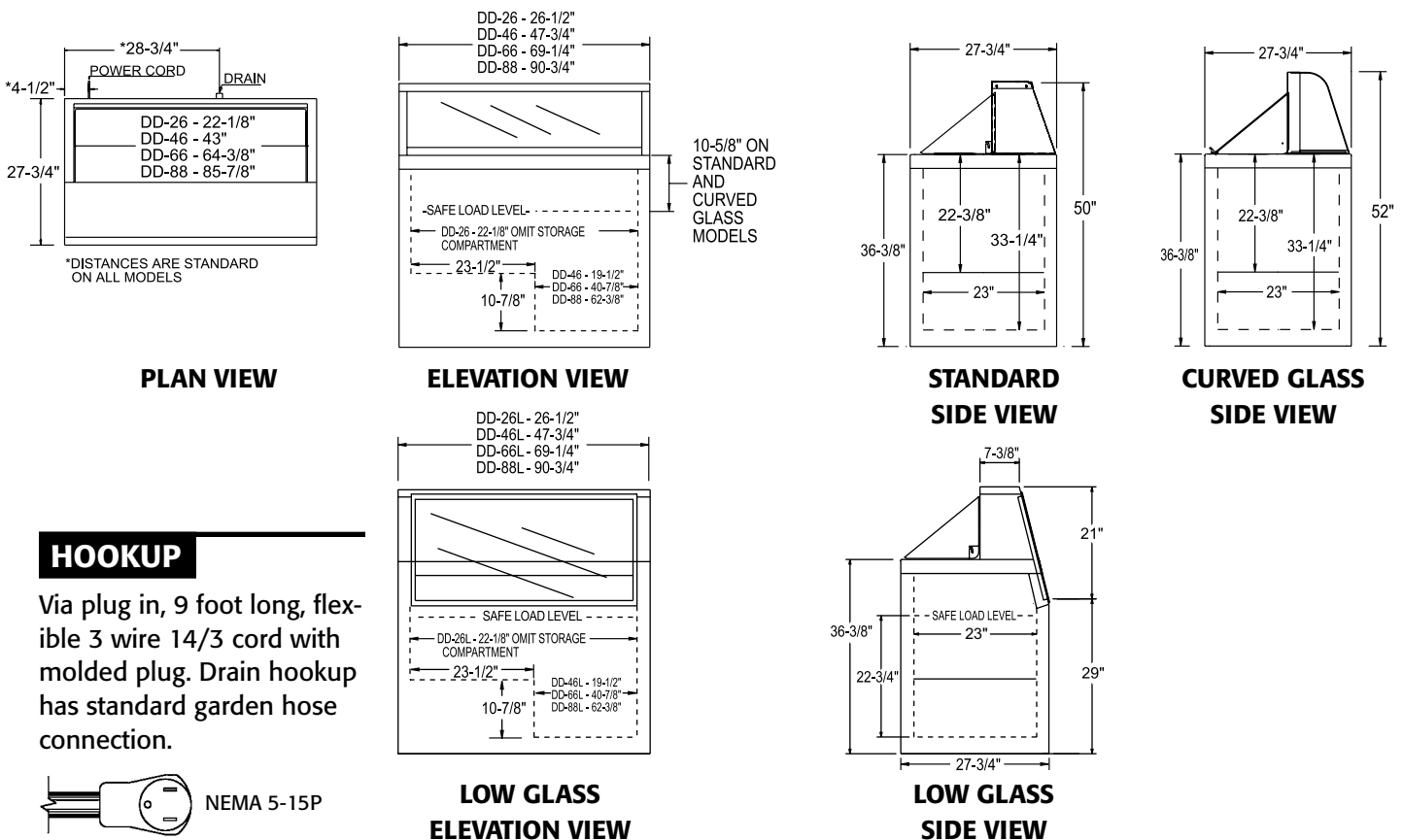

### HOOKUP

Via plug in, 9 foot long, flexible 3 wire 14/3 cord with molded plug. Drain hookup has standard garden hose connection.



### BID SPECIFICATIONS

Item no. DD- \_\_\_\_\_  
 Provide \_\_\_\_\_ ( ) Deluxe Ice Cream Dipping/Display Merchandiser(s), Master-Bilt model no. DD- \_\_\_\_\_.

Cabinet to have independent on/off compressor and light switch. Cabinet to be provided with drain connection, stainless steel top and superstructure, tempered plated glass viewing window and interior fluorescent

lighting. Cabinet is to have rear air intake and discharge. Standard leveling legs provided to correct for unlevel flooring situations. Hanging frost shields with mounting screws offered as an accessory (consult your Master-Bilt representative for additional accessories).

Cabinet will be provided with 9 foot cord and molded plug.

DD-26/26CG/26L and DD-46/46CG/46L will use R-134a refrigerant while DD-

66/66CG/66L and DD-88/88CG/88L will use R-404A refrigerant. The temperature range will be 5° to -5°F (-15° to -21°C). All models except DD-26/26CG/26L to be supplied with a refrigeration system containing low maintenance bare tube condenser coil.

Cabinet to have standard limited four year extended compressor warranty and one year limited parts and labor warranty. Cabinet to be UL, C-UL and NSF listed.

**NOTE: Cabinet designed for optimum performance in air-conditioned area at 75°F ambient and 55% R.H. All specifications subject to change without notice.**