



DP12

Mobile Proofers from Doyon

Doyon proofers provide uniform proofing from top to bottom with their unique even flow system. These units have been designed for small and medium production of bakery products. If you have a limited budget, the non-insulated proofer is the solution for you. They come with solid state heat and humidity controls. For higher production, the insulated cabinet would be a better alternative for you as it will keep its temperature more constant even if you open the door frequently. It's the easiest way to proof!

Versatility:

Croissants, bagels, pastries, breads, rolls and much more.

DP12 DP12I (insulated)

“Superior **quality** product
at an **affordable** price !”

MOBILE HALF HEIGHT PROOFER Standard Features DP12

- Polycarbonate door
- Magnetic door gasket
- Adjustable temperature control up to 110°F (44°C)
- Exclusive rust proof, scratch proof shelving
- Aluminum construction
- Removable power assembly for easy cleaning and maintenance
- Powerful, efficient airflow system maintains the right combination of heat and humidity
- Lift-off hinges
- Perimeter bumpers
- Water catch pan
- NEMA 5-20P cord and plug
- 1500 watts
- 5" (127 mm) non-marking swivel casters with brakes
- ETL & NSF listed
- One year parts and labor limited warranty

OPTIONAL

- Solid aluminum door

Standard Features DP12I

- Polycarbonate door
- Magnetic door gasket
- Adjustable temperature control up to 110°F (44°C)
- Insulated cabinet
- Exclusive rust proof, scratch proof shelving
- Aluminum construction
- Removable power assembly for easy cleaning and maintenance
- Powerful, efficient airflow system maintains the right combination of heat and humidity
- Lift-off hinges
- Perimeter bumpers
- Water catch pan
- NEMA 5-20P cord and plug
- 1500 watts
- 5" (127 mm) non-marking swivel casters with brakes
- ETL & NSF listed
- One year parts and labor limited warranty

OPTIONAL

- Solid aluminum door

OVERALL DIMENSIONS

DP12 22 13/16" W X 33 5/16" D X 30 5/16" H
(584 mm X 838 mm X 762 mm)
DP12I 23 5/16" W X 33 7/8" D X 31 7/16" H
(590 mm X 842 mm X 800 mm)

PROOFER INTERIOR DIMENSIONS

DP12 18 1/8" W X 27 1/2" D X 15 5/8" H
(460 mm X 699 mm X 397 mm)
DP12I 18 1/8" W X 27 1/2" D X 15 5/8" H
(460 mm X 699 mm X 397 mm)

ELECTRICAL SYSTEM

DP12 120V- 12.5A
DP12I 120V- 12.5A

CAPACITY

Standard sheet pans 18" X 26" (457 mm X 660 mm): 11 pans
Half size sheet pans 18" X 13" (457 mm X 330 mm): 22 pans

Shelf spacing 1 1/2" (38 mm)

FINISH

Aluminum

SHIPPING WEIGHT

DP12 100 lb (45 kg) approximately
DP12I 100 lb (45 kg) approximately

Electrical service connection and water inlet are located at the back of the unit.

Specifications and design subject to change without notice.

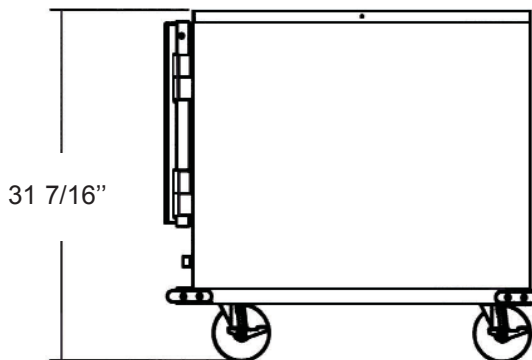
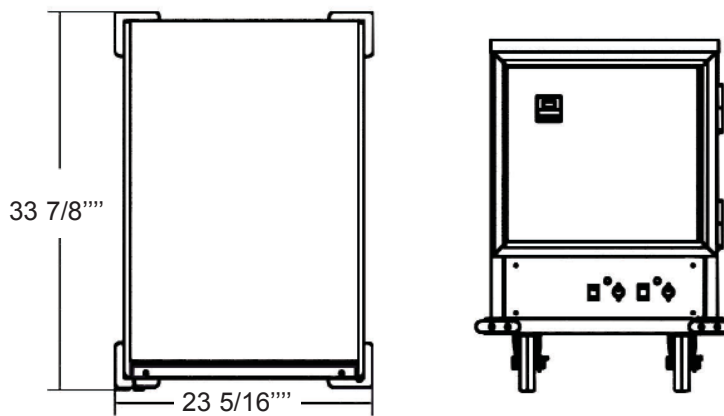

Your local distributor:

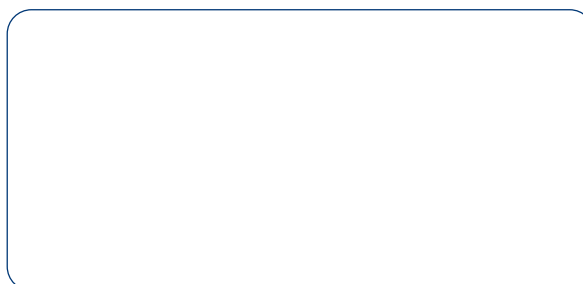

1255, rue Principale
Linière, Beauce, Québec, Canada G0M 1J0

Tel: (418) 685-3431 Fax: (418) 685-3948
Canada : (800) 463-1636 U.S.: (800) 463-4273
E-Mail : doyon@doyon.qc.ca Internet: