



SIZE:
23,75 x 25,00 x H32,28 inch

Cycle period: 2 minutes

Capacity per hour:
Baskets/H 30

- Undercounter dishwasher;
- Stainless steel construction 18/10AISI 304;
- Wash cycle time: 2 minutes;
- Wash and rinse temperature thermometers;
- Stainless steel lower and upper rotating wash arms;
- Stainless steel lower rotating rinsing and upper fixed;
- Extractable control panel for an easy maintenance;
- Rinse aid dispenser;
- Detergent pump;
- Automatic tank loading;
- Door opening safety device;
- Thermocontrol: device which guarantees the selected temperature for every rinsing cycle even in case of non-stop work;
- Security thermostat;

• Certifications: UL, UL Sanitation;



DSP4

Accessories:

- 1 basket for dishes;
- 1 generic basket;
- 1 cutlery container;

OPTIONS,

- Stainless steel base H17,72 inch,

Specifications	DSP4	
VOLTAGE	208 V1ph 60Hz	V
WASHING PUMP	650	W
WASH TANK ELEMENTS	2000	W
RINSE TANK ELEMENTS	3000	W
TOTAL RATING	3650	W
MAX CURRENT INTENSITY	20	A
PLATES CLEARANCE	11,81	inch
WORK HEIGHT	12,40	inch
TANK CAPACITY	15	Lt.
BOILER CAPACITY	3	Lt.
PUMP DELIVERY	260	Lt./min
WATER CONNECTION	131	°F
WATER CONSUMPTION PER CYCLE	2,4	Lt.
WATER CONSUMPTION PER HOUR	72	Lt.
WATER PRESSURE	20±5	psi
WATER HARDNESS	5 ÷ 10	TH(°F)
RINSING WATER TEMPERATURE	179 ÷ 194	°F
WATER INLET	3/4"	"G
WATER OUTLET	1"1/4	"G
NET WEIGHT	43	Kg
GROSS WEIGHT	48	Kg
PACKING SIZE	l'24,80xL28,37xH44,09	inch
NOISE LEVEL	<70	dB(A)

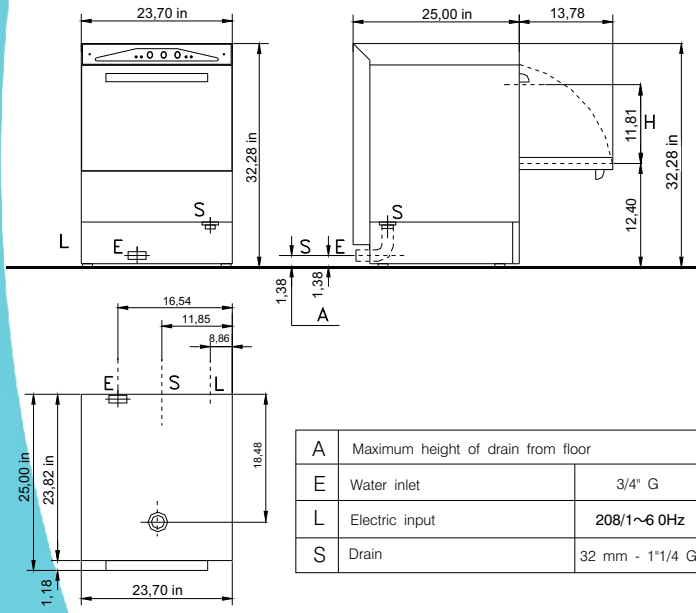
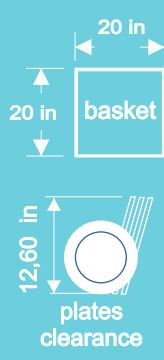

The manufacturer reserves the right to make modifications of materials and models without warning.