



COMPACT - EFFICIENT - ECONOMICAL



DTU-U60-48R Shown.
(Dishwasher by others)

FEATURES:

- Tile edge for ease of installation.
- Features a 5" deep bowl.
- Table is furnished with 10-1/2" splash with a 2" return.
- Stainless Steel Legs Stainless Steel Legs with Welded Cross Bracing with Stainless Steel Bullet Feet.

CONSTRUCTION:

- All TIG welded.
- Welded areas blended to match adjacent surfaces and to a satin finish.
- Gussets welded to a stainless steel support channel.

MECHANICAL:

- Faucet holes in SPLASH punched on 8" centers (Faucet not included).
- Waste Drain included.

MATERIAL:

- LEGS are 16 ga. 304 Stainless Steel.
- TOP with bowl, drainboard, splash and rolled rims are fabricated using 16 gauge stainless steel type "304" series.

STAINLESS STEEL
**DISHTABLE
UNDERCOUNTER**

Item #: _____ Qty #: _____
 Model #: _____
 Project #: _____

Model #	Length	Wt.
DTU-U60-48L	48"	80 lbs.
DTU-U60-48R	48"	80 lbs.
DTU-U60-72L	72"	115 lbs.
DTU-U60-72R	72"	115 lbs.

Left or Right designation is determined by sink location.

**Optional
Basket with Welded
Slide Bar**



DTA-100

20" x 20"

ACCESSORIES	Model #
Faucet	
Prerinse Basket	

DIMENSIONS and SPECIFICATIONS

TOL ± .500"

ALL DIMENSIONS ARE TYPICAL

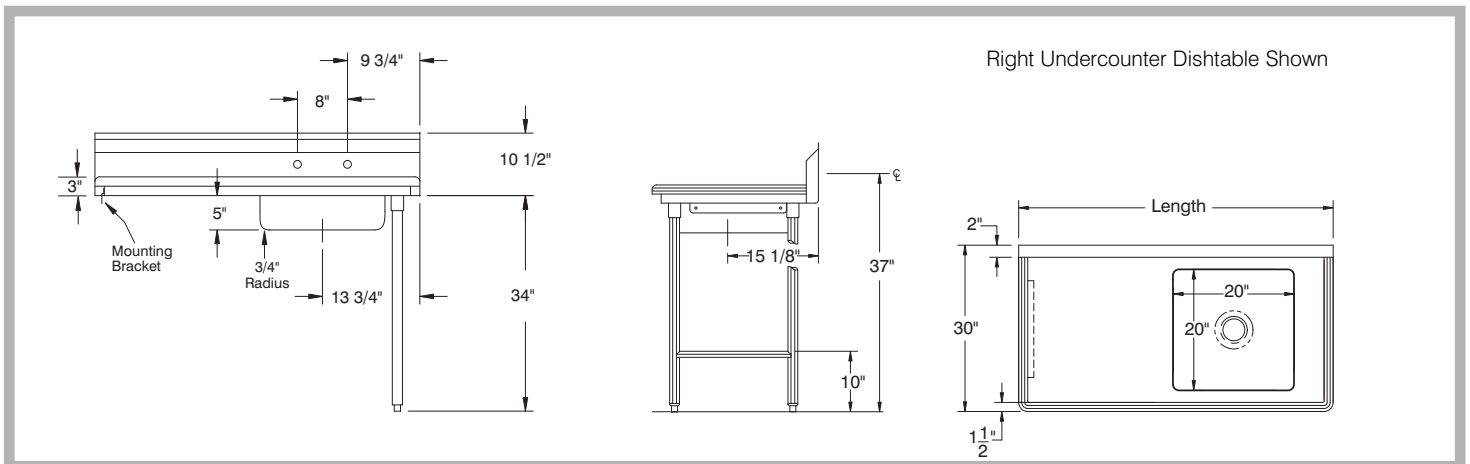

Customer Service Available To Assist You 1-800-645-3166 8:30 am - 8:00 pm E.S.T.
 Email Orders To: customer@advancetabco.com. For Smart Fabrication™ Quotes, Email To: smartfab@advancetabco.com or Fax To: 631-586-2933

NEW YORK
Fax: (631) 242-6900

GEORGIA
Fax: (770) 775-5625

TEXAS
Fax: (972) 932-4795

NEVADA
Fax: (775) 972-1578