



MODEL E ENERGY SAVER
LOW WATER
MACHINES

**USES ONLY
.93
Gallons Of Water
Per Cycle!**



**MODEL E
AVAILABLE IN STRAIGHT
AND CORNER MODEL**



**MODEL E-3
(3 DOORS OPEN)
AVAILABLE FOR STRAIGHT
THROUGH AND CORNER
OPERATION.**



**MODEL E EXT
WITH 20-1/2" DOOR OPENING
AVAILABLE IN STRAIGHT
AND CORNER MODEL**

FEATURES AND FACTS:

- **Energy Star Qualified.**
- 40 racks / 160 covers per hour.
- Economical to operate. **Uses only .93 gallons of water per cycle.**
- All stainless steel construction assures long life and years of trouble free operation.
- Unique spray arm system features upper and lower stainless steel wash arms with reinforced end caps.
- Top mounted controls include built-in chemical pumps and delimiting system for dealing with scale.
- Auto start/stop makes operation safe and easy.
- New integrated scrap tray prevents food soil from entering drain system.
- Airgap fill system.

CONVERTIBLE CORNER TO STRAIGHT AND STRAIGHT TO CORNER.

Available Options

- Sanitizer Alarm
- Alternative cycle times
- Pull Pins
- Stainless Steel Scrap Trap Up Grade
- The "TEMP-SURE" requires a separate 208-240v 3 phase 40 amp power supply
- 3 Doors open
- Extended (Tall) version





MODEL E ENERGY SAVER
LOW WATER
MACHINES

WARNING: Plumbing connections must be made by a qualified service company who will comply with all available Federal, State, and Local Health, Plumbing and Safety codes.

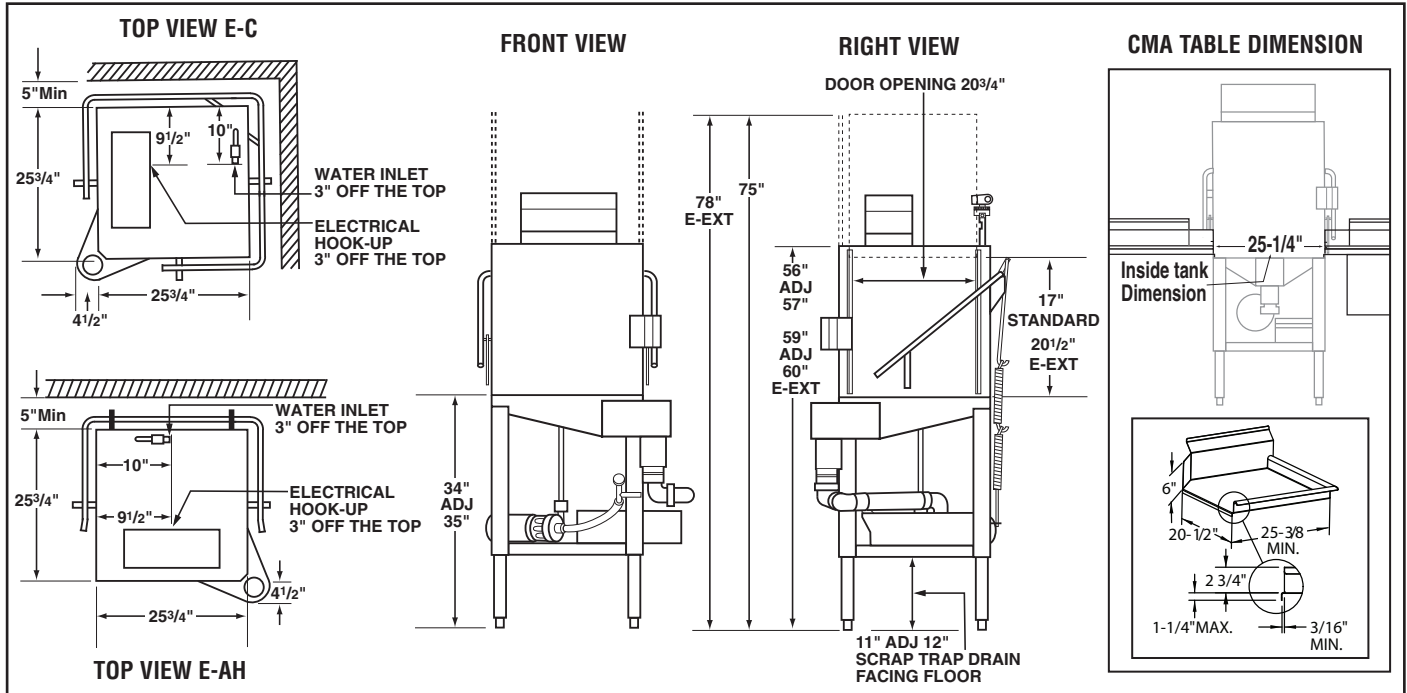

Specifications:

MODEL E/E-3/E-EXT	USA	METRIC	USA	METRIC
OPERATING CAPACITY				
RACKS PER HOUR (NSF RATED)	40	40		
OPERATING CYCLE				
WASH TIME-SEC	45	45		
RINSE TIME-SEC	30	30		
DWELL TIME-SEC	15	15		
TOTAL CYCLE TIME	90	90		
PUMP CAPACITY	52 GPM	(197 LPM)		
OPERATING TEMPERATURE				
REQUIRED	120°F	(49°C)		
RECOMMENDED	140°F	(60°C)		
WATER CONSUMPTION				
PER RACK	.93 GAL.	(3.53 L)		
PER HOUR	37 GPH	(139 LPH)		
WATER REQUIREMENTS				
WATER INLET	1/2"	(1.27cm)		
DRAIN-I.P.S.	2"	(5.1cm)		
WASH PUMP MOTORS HP			1	1
DIMENSIONS				
DEPTH	25-3/4"	(65.4cm)		
WIDTH (OUTSIDE DIMENSION)	25-3/4"	(65.4cm)		
HEIGHT	56"-57"	(142.2cm-144.8cm)		
	E-EXT 59"-60"	(150cm-152cm)		
STANDARD TABLE HEIGHT	34"	(86cm)		
MAXIMUM CLEARANCE FOR DISHES	17"	(43cm)		
	E-EXT 20-1/2"	(52cm)		
STANDARD DISHRACK DIMENSIONS	1	1		
	19-3/4"X19-3/4"	(50X50cm)		
ELECTRICAL RATING	VOLTS	AMPS		
	115	16		
SHIPPING WEIGHT APPROXIMATE				
	218#	(98.7kg)		
	E-EXT L 260#	(117.8kg)		

Summary Specifications: Model E/E-3/E-EXT

CMA Energy Miser model E/E-3/E-EXT(Extended 20-1/2" door opening) low temperature, chemical sanitizing commercial dishwashers meet ETL, UL, and CUL sanitation and construction standards WITHOUT the use of BOOSTER or TANK HEATERS. The model E/E-3/E-EXT is constructed entirely of stainless steel. Each unit automatically washes, rinses and sanitizes utensils in standard 19-3/4"x19-3/4" racks. Units come with standard upper and lower stainless steel wash arms. **Note: This machine does not have built-in heaters, therefore produces no steam.**

