

**NOTE:**

1. ALL VISIBLE WELDS TO BE GROUND SMOOTH & POLISHED TO A MATCHING FINISH
2. ALL NON-VISIBLE WELDS TO BE GROUND SMOOTH & PAINTED
3. ALL EDGES TO BE SMOOTH & FREE FROM BURRS
4. ALL TUBS TO BE DIE STAMPED MIN. 1/4" TO INSURE PROPER DRAINAGE, ALL DRAIN HOLES TO BE RECESSED MIN. 1/8"
5. 2" 20 GA. S/S VERMIN STRIP TO BE SECURED TO TUB SEAM PERIMETER BY MEANS OF STITCH WELDING. ALL WELD & COLOR TO BE REMOVED. SEAM TO BE SEALED USING NSF APPROVED SILICONE.
6. DRAIN BOARDS ARE TO BE DIPPED MIN. 1/4" TO INSURE PROPER DRAINAGE.

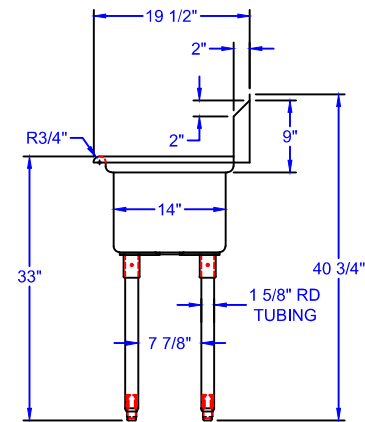
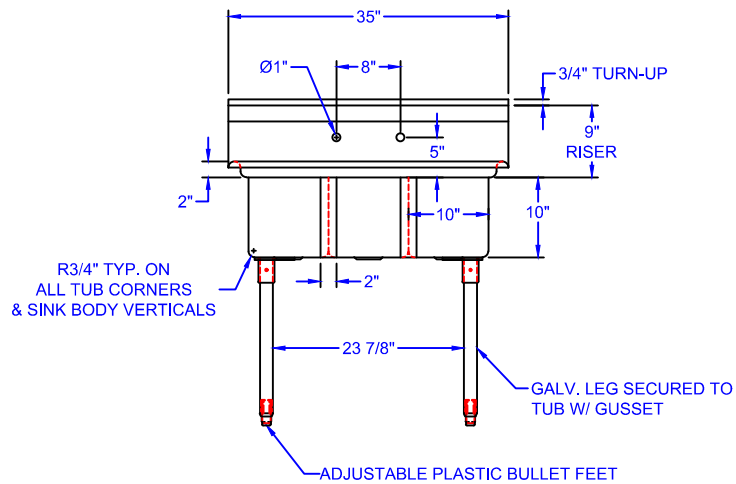

**MATERIALS**

DECK: 18GA. S.S.  
BASE: GALV.



**JOHN BOOS & CO.**

315 SOUTH FIRST STREET  
P.O. BOX 609  
EFFINGHAM, IL. 62401  
(217) 347-7701 / FAX (217) 347-7705

E-MAIL: sales@johnboos.com Web Site: www.johnboos.com

**REVISIONS:**

12-5-08 Updated border. cs

**JOHN BOOS & COMPANY**

**E SERIES**

THIS DRAWING AND THE DESIGN SHOWN ARE THE PROPERTY OF JOHN BOOS & CO. REPRODUCTION, INFRINGEMENT OR ANY OTHER UNAUTHORIZED USE OF THIS DRAWING WITHOUT THE WRITTEN CONSENT OF JOHN BOOS & CO. WILL BE SUBJECT TO LEGAL ACTION.

SALES ORDER NUMBER:

JK

DRAWN BY:

7-28-07

DATE:

1/2"=1"

SCALE:

MODEL NUMBER: E388-1014-10

QUANTITY:

ITEM NUMBER:

ROOM NUMBER:

QUAD LOCATION:

COMPARTMENT SINKS

SHEET NUMBER: