

Project _____

Item Number _____

Quantity _____

Convection Oven



* Shown with optional extraction hood and proofer

4 Tray Bakery Oven

Models:

- ECOW4000- 26" x 18" Tray Size**

Bakery Oven

Features:

- Powerful and economical convection oven designed uniform cooking to suit any bakery needs
- Stackable in many different configurations when paired with other ECO Bakery Ovens
- Ovens can be outfitted with wheel for easy mobility or feet for fixing location

Standard Features:

- Tray Size: 26" x 18"
- Digital, standard touch screen control panel
- Single speed convection fan
- Left or right door opening orientation
- Cooking alarm/buzzer

Optional Features:

- 4 speed convection fan
- Puff pastry option
- Steam option
- Exhaust hood
- Hygrometry proofer
- 9.5in(240mm), 21.7in(550mm), 35.8in(910mm) stand(s)

Univex Corporation

Warranty:

- Two year, on-site parts and labor

Warranty Details

The oven carries a two year, on-site parts and labor warranty against any flaws in materials and workmanship. This period begins on the date of the purchase and, provided the unit is used in accordance with our instructions, is in full effect for two years from that date. Any work performed under this warranty must be performed between the hours of 8am and 5pm Monday through Friday. Univex will not pay for overtime charges for work performed other than during normal business hours. Damage incurred in transit or from installation error, accident, alteration or misuse is not covered. Univex shall not be liable for any consequential compensatory, incidental, or special damages. Contact the Univex service department for any warranty claims. Ovens with steam may require water filtration depending upon water quality of oven location. If scaling or damage is caused by too hard or too soft unfiltered water warranty may be voided.



We Raise the Bar. We Set the Standard.

Convection Bakery Ovens

Electric

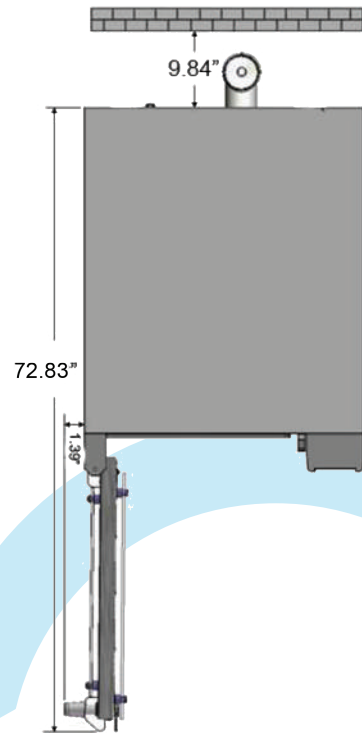
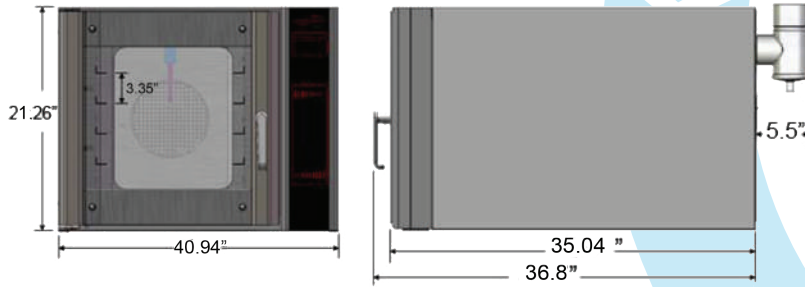

Oven with optional decorative hood and stand



Oven with optional decorative hood and proofer

*For information about proofer reference EECO Proofer Spec Sheet

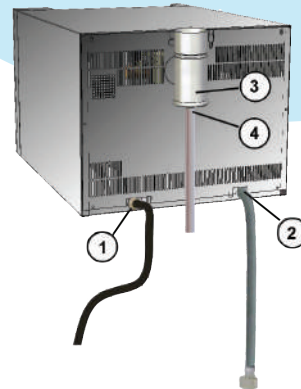

①	Electrical Connection	~6' Electrical Cord Provided
②	Water Inlet (Steam)	ø 3/4"
③	Exhaust Pipe	ø 3" w/o hood ; ø 6" w/ hood
④	Exhaust Pipe Purge	ø .79"

Shipping Information:

Freight Class: 85
 Weight: 326 lbs
 Shipping Weight: 375 lbs
 Crate Dimensions (W x D x H): 45"x40"x30"

Voltage: 208-240/60hz/3PH
 Amps: 26.8



Univex Corporation
www.Univexcorp.com

3 Old Rockingham Rd
 Salem, NH 03079
 United States of America

TEL: 800.258.6358
 INTL TEL: 603.893.6191
 FAX: 800.356.5614
 INTL FAX: 603.893.1249