



Electric Fryer Countertop – 30 lbs.

Models □ EF-30i 208V □ EF-30i 240V □ EF-308iNT 208V □ EF-30iNT 240V

PRODUCT:

QUANTITY:

ITEM:

Designed Smart

Compact Design with High Output

- Fits in tight counter space and is available in a “large basket” capacity version (EF-30i) or versatile “twin 15lb” version (EF-30iNT)
- EF 30i and EF-30iNT come standard with two full size baskets. Please specify if requesting twin 15 lb. baskets on EF-30iNT.
- Reaches frying temperatures fast, and maintains heat levels from one load to the next

Easy to Operate

- Yellow cycling light alerts operator that unit is ready for next batch of fries.
- Unit automatically shuts down if frying compound overheats
- Stainless steel exterior is easy to wipe clean



Model: EF-30i

APW Wyott Design Features

- Stainless steel construction
- 4” (10cm) legs
- Front panel permits easy servicing
- Lift-out, one piece tank with carrying handles. Large foaming area above frying compound level
- Insulating air pocket surrounds tank for improved temperature control
- Swing up, pyrolytic heating elements with two-stage locking mechanism
- Cold zone under heating elements reduces circulation of particles in frying compound
- Front-located adjustable thermostat (200 °F / 93 °C to 400 °F / 204 °C) with on/off switch
- High-limit protection control circuit breaker which automatically trips should frying compound overheat
- Front panel yellow cycling light indicates that frying temperature has been reached
- High temperature 392 °F (200 °C) internal wiring
- Nickel-plated twin fry baskets with front hangers

*Warranty does not include rock grates, cooking grates, burners shields or fireboxes.

Reliability backed by APW Wyott’s Warranty

All APW Wyott cooking equipment is backed by our 2-year parts and labor warranty. *

•Certified by the following agencies:



See reverse side for product specifications.



APW Wyott Foodservice Equipment Company
1307 N Watters Rd.; Suite 180 | Allen, TX 75013 | (800) 527-2100 Fax (214) 565-0976
www.apwwyott.com | info@apwwyott.com
revised 060113cp

PRODUCT:

QUANTITY:

ITEM:

PRODUCT SPECIFICATIONS

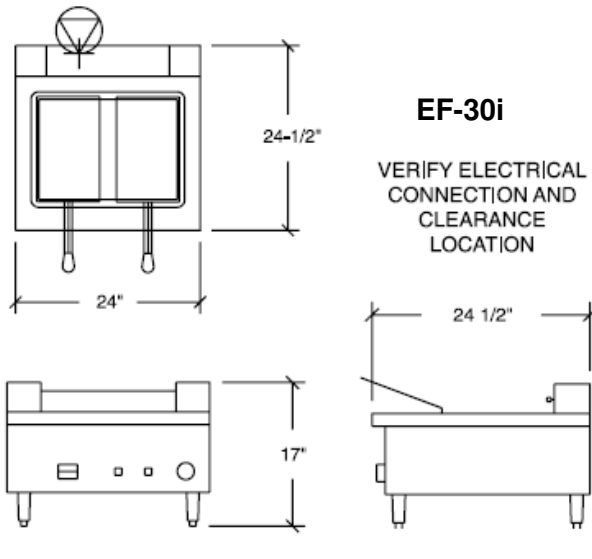

Construction:

Heavy-duty stainless steel body. Fry baskets are constructed of nickel-plated steel. 4" adjustable heavy-duty stainless steel legs.

Electrical Information:

Units are wired for hard wiring in the field.

Electrical Specifications:

EF-30i 208V::	208V, 12KW, 57.7Amps-1 Phase
	208V, 12KW, 50 Amps-3 Phase
EF-30i 240V:	240V, 12KW, 57.7Amps-1 Phase
	240V, 12KW, 43.3 Amps-3Phase
EF-30iNT 208V:	208V, 8.56KW, 41.2Amps-1 Phase
	240V, 11.4KW, 47.7Amps-1 Phase

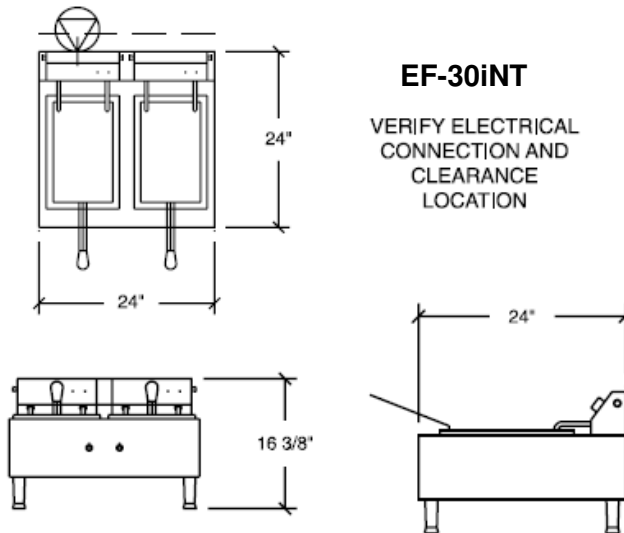

Capacity:

EF-30i:	30 lbs (13.6) Produces up to 60 lbs of raw-to-done potatoes per hour.
EF-30iNT:	30 lbs (13.6) Produces up to 60 lbs of raw-to-done potatoes per hour

Basket Size:

Full Size	6 1/4" H x 7 1/4" W x 11 2/5" D
-----------	---------------------------------

Overall Dimensions:

EF-30i:	17" H x 24"W x 24 1/2"D (43.2 cm x 61 cm x 62.2 cm)
EF-30iNT:	16 3/8" H x 24" W x 24" D (41.6 cm x 61cm x 61 cm)

Shipping:

EF-30i:	92 lbs. (41.8 kg)
EF-30iNT:	66 lbs. (29.9 kg)

Freight Class: 85

FOB: Cheyenne, WY

*APW Wyott reserves the right to modify specifications or discontinue models without incurring obligation.