



SALAD SPINNER ES-100

Capacity per cycle: 6 Kg. / 13 lbs.



FEATURES AND BENEFITS

- ✓ Sammic salad spinners dry lettuce and other vegetables in as low as 1-3 minutes owing to their fast speed (900 r.p.m), ensuring good product quality.
- ✓ Equipped with powerful three-phase motors controlled by highly reliable electronic speed variator, which enables the salad dryer to be connected to a single-phase electrical mains supply.
- ✓ Stainless steel construction.
- ✓ Lightweight and removable stainless steel basket.
- ✓ Compact geometry: easily fits under conventional standard countertops.
- ✓ Equipped with castors allowing the operator to wheel unit around the kitchen and under a countertop for easy storage.
- ✓ Transparent, heavy duty lid for ease of control.
- ✓ Lid equipped with a self-opening mechanism, for ease of access to basket.
- ✓ User-friendly, waterproof control panel. Advanced features
- ✓ Electronic timer with 3 fixed cycles.
- ✓ Weight distribution detection system (VCS) to prevent rattling of the unit. Self lock-in mechanism to ensure basket is properly secured before cycle starts.
- ✓ Braking system safety mechanism: allowing basket to stop turning as soon as lid opens.
- ✓ An indicator appears when the door is open.

INCLUDES

- ✓ Castors with brake.
- ✓ Stainless steel drying basket.



SALES DESCRIPTION

Fast, sleek, quiet, user-friendly, safe, smooth running commercial salad spinner, designed to efficiently dry up to 6 Kg. / 13 lbs. of salad per cycle at a maximum speed of 900rpm.

Portable. Equipped with locking wheels. Cycle memory. 2-speed-appliance.



sammic | www.sammic.us
Food Service Equipment Manufacturer

usa@sammic.com
1225 Hartrey Avenue
60202-1056 Evanston, IL

phone +1 (224) 307-2232
toll free +1 844 275 3848



Project	Date
Item	Qty
Approved	

FOOD PREPARATION EQUIPMENT
COMMERCIAL SALAD SPINNERS

specification sheet
update 05/04/18



SALAD SPINNER ES-100

Capacity per cycle: 6 Kg. / 13 lbs.

SPECIFICATIONS

Capacity per load: 13 lbs.
 Drainer hourly production: 250 lbs. - 800 lbs.
 Timer (min-max): 60 " - 120 " - 180 "
 Motor speed: 900 rpm
 Total loading: 0.75 Hp
 Electrical supply: 120V / 50-60 Hz / 1~ (5 A)

External dimensions (WxDxH)

- ✓ Width: 21.3 "
 - ✓ Depth: 29.5 "
 - ✓ Height: 26.2 "
- Net weight: 106 lbs.

Crated dimensions

660 x 820 x 860 mm
 Gross weight: 55 Kg.

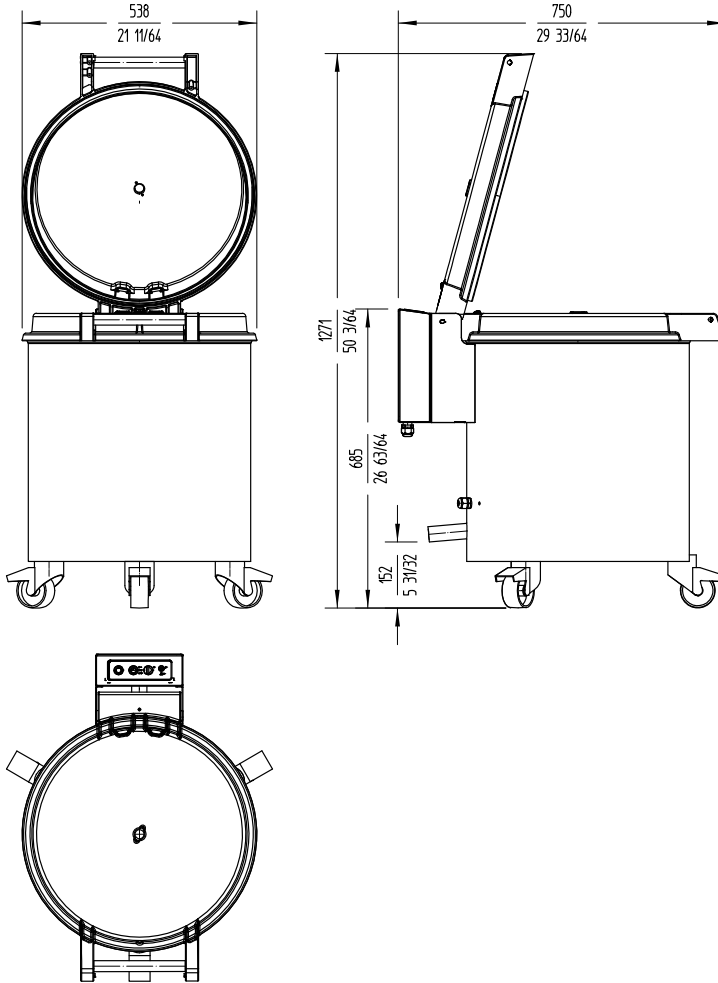

AVAILABLE MODELS

1000702 Salad dryer ES-100 120/50-60/1

* Ask for special versions availability

sammic | www.sammic.us
 Food Service Equipment Manufacturer

usa@sammic.com phone +1 (224) 307-2232
 1225 Hartrey Avenue toll free +1 844 275 3848
 60202-1056 Evanston, IL



Project	Date
Item	Qty
Approved	

specification sheet
 update 05/04/18

FOOD PREPARATION EQUIPMENT
 COMMERCIAL SALAD SPINNERS