

S T E A M

VULCAN**EL & ET SERIES
ELECTRIC FULLY JACKETED KETTLE**

Model EL80

**SPECIFICATIONS**

Electric fully jacketed stationary kettle. Kettle is mounted on 2" diameter legs with adjustable flanged feet. The kettle liner is constructed out of 316 Series stainless steel. Spring assist hinged stainless steel cover with condensate ring and drop down lift handle with heavy duty pivot assembly that includes a yolk style mount with tie bar. The dish shaped interior bottom is sloped to the front for a smooth product flow through a mounted, tapered, 2" plug type food product draw-off valve. Draw-off includes opening strainer. Graduated measuring rod. Furnished standard with a 15 PSI relief valve, magnetic conductor and electric heating elements, on/off switch with signal light and thermostat control, low water cut-off control and a pressure limit switch and pressure gauge. Power supply to be (208) (240) volt, 3 ph, 50/60 Hz standard.

UL listed. Classified by UL to NSF Standard #4. Meets ASME code.

<input type="checkbox"/> EL80	80 gallons	303 liters
<input type="checkbox"/> ET100	100 gallons	379 liters
<input type="checkbox"/> ET125	125 gallons	473 liters
<input type="checkbox"/> ET150	150 gallons	568 liters

STANDARD FEATURES

- Kettle fully steam jacketed.
- Mounted on stainless steel 2" diameter legs with adjustable flange feet.
- 316 Series stainless steel jacket liner.
- Reinforced hinged stainless steel cover with condensate ring and drop down lift handle with heavy duty pivot assembly that includes a yolk style mount with tie bar.
- Kettle interior bottom sloped to front for smooth product flow through a mounted, tapered, plug type food product draw-off valve of standard 2" diameter.
- Draw-off opening strainer.
- Graduated measuring rod.
- Faucet bracket.
- On/off switch with signal light and thermostat control. 15 PSI relief valve, magnetic conductor and electric heating elements, low water cut-off control and a pressure limit switch with pressure gauge.
- Available standard 208 volt, 3 phase, 50/60 Hz or 240 volt, 3 phase, 50/60 Hz.
- One year limited parts and labor warranty.

OPTIONS

- Three inch compression tangent draw-off valve with perforated strainer.
- Security facility package.
 - a. Security type fasteners with tack welds.
 - b. Stainless steel step over draw-off valve with chain.
- Increase to 43.2 kW for 60 gallon models (3 phase only).
- 480 volt, 3 phase, 50/60 Hz.
- Second year extended limited parts and labor warranty.

ACCESSORIES (Packaged & Sold Separately)

- Perforated stainless steel triple basket assembly.
- Clean-up kit, includes draw-off brush, clean-up brush and paddle scrapper with 40" handle.
- Stainless steel 48" whip.
- Heat deflector shield.
- (12") (18" double jointed) single pantry lead-free faucet.
- (12") (18" double jointed) double pantry lead-free faucet.
- Double pantry washdown hose with 16" add-on lead-free faucet with vacuum breaker.
- Double pantry washdown hose lead-free with vacuum breaker.
- Double pantry pot filler lead-free with vacuum breaker.

VULCAN

a division of ITW Food Equipment Group LLC

P.O. Box 696 ■ Louisville, KY 40201 ■ Toll-free: 1-800-814-2028 ■ Local: 502-778-2791 ■ Quote & Order Fax: 1-800-444-0602



EL & ET SERIES ELECTRIC FULLY JACKETED KETTLE

SERVICE CONNECTIONS:

C2 Water: Faucet location.

NOTE:

- Dimensions which locate the above connections have a tolerance of + or -3" (+ or -75 mm).
- Installation of backflow preventers, vacuum breakers and other specific code requirements is the responsibility of the owner and installer. It is the responsibility of the owner and installer to comply with local codes.
- Plastic drains are not recommended due to inherent limited temperatures of the plastic. Boiler purge temperatures may exceed 180°F. The installer may be required to provide means to reduce boiler purge water temperature to be that of the condensate temperature of 140°F or less.
- This appliance is manufactured for commercial installation only and is not intended for home use.

BRIMFUL CAPACITIES:				
MODEL	GALLONS	QUARTS	LITERS	4 OZ. SVGS.
EL80	80	320	303	2560
ET100	100	400	379	3200
ET125	125	500	473	4000
ET150	150	600	568	4800

POWER			
VOLT	PH	KW	
		36	43.2
208	3	100	120
240	3	86.6	104
480	3	43.2	52

1 Add 2" to "C" & "D" for 3" compression tangent draw-off valve.

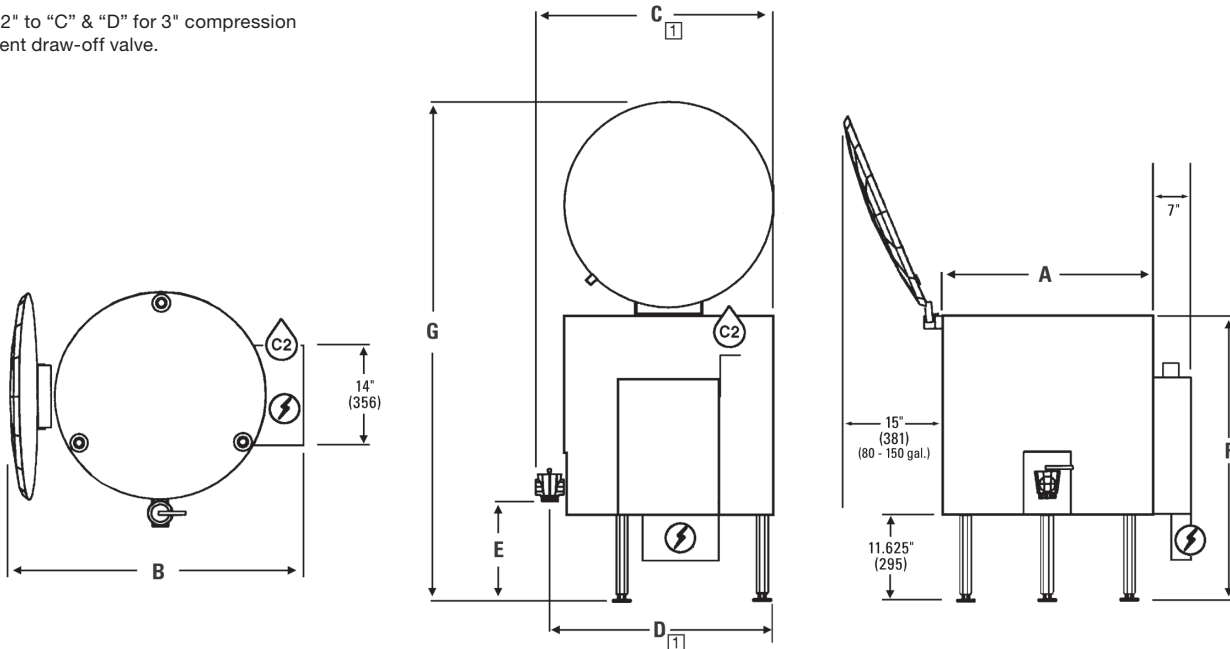

MODEL	CAPACITY	KW	A	B	C	D	E	F	G	H	I
EL80	80 gallons 303 liters	36	36½ (927)	58½ (1486)	41½ (1054)	39½ (1003)	13 (330)	40 (1016)	79 (2007)	20¾ (527)	22½ (572)
ET100	100 gallons 379 liters	36	36½ (927)	58½ (1486)	41½ (1054)	39½ (1003)	13 (330)	45 (1143)	84 (2134)	20¾ (527)	22½ (572)
ET125	125 gallons 473 liters	36	36½ (927)	58½ (1486)	41½ (1054)	39½ (1003)	13 (330)	52 (1321)	91 (2311)	20¾ (527)	22½ (572)
ET150	150 gallons 568 liters	36	36½ (927)	58½ (1486)	41½ (1054)	39½ (1003)	13 (330)	58½ (1486)	97½ (2477)	20¾ (527)	22½ (572)



a division of ITW Food Equipment Group LLC

P.O. Box 696 ■ Louisville, KY 40201 ■ Toll-free: 1-800-814-2028 ■ Local: 502-778-2791 ■ Quote & Order Fax: 1-800-444-0602

NOTE: In line with its policy to continually improve its products, Vulcan reserves the right to change materials and specifications without notice.