



**John  
BOOS**  
Since 1887

ITEM #: \_\_\_\_\_ QTY: \_\_\_\_\_

MODEL #: \_\_\_\_\_

PROJECT NAME: \_\_\_\_\_

3601 S. Banker St. Effingham, IL 62401 • P.O. BOX 609 • Ph: (888) 431-2667 • Fax: (800) 433-2667

## UNDERBAR SINKS

### FEATURES:

- FABRICATED BOWLS: 10" X 14" X 10"
- STAMPED RIBBED DRAIN BOARDS
- RAISED MARINE EDGE ON FRONT & SIDES
- GALVANIZED LEGS AND BRACING,

### CONSTRUCTION:

- TOP: STAINLESS STEEL TOPS ARE TIG WELDED, EXPOSED WELDS ARE POLISHED TO MATCH ADJACENT SURFACE.

### MATERIAL:

- TOP: 18GA 300 SERIES STAINLESS STEEL
- BRACING: GALVANIZED
- LEGS: GALVANIZED
- GUSSETS: GALVANIZED
- FEET: PLASTIC

### INCLUDES:

- ECONOMY FAUCET (PBF-4-D-10LF)
- OVERFLOW PIPES (PB-OVF-BS)



### UNDERBAR SINKS

| MODEL #     | QTY |
|-------------|-----|
| EUB2S36-1RD |     |
| EUB2S36-1LD |     |
| EUB2S48-1RD |     |
| EUB2S48-1LD |     |
| EUB2S48-2D  |     |
| EUB3S40     |     |
| EUB3S48-1RD |     |
| EUB3S48-1LD |     |
| EUB3S60-1RD |     |
| EUB3S60-1LD |     |
| EUB3S60-2D  |     |
| EUB3S72-2D  |     |
| EUB3S84-2D  |     |
| EUB3S96-2D  |     |
| EUB4S72-2D  |     |
| EUB4S84-2D  |     |
| EUB4S96-2D  |     |



EUB3S72-2D  
SHOWN WITH FAUCET  
MODEL #: PBF-4-D-10LF

### OPTIONAL ACCESSORIES

| MODEL #              | QTY |
|----------------------|-----|
| SPEED RAILS          |     |
| STAINLESS STEEL LEGS |     |

# UNDERBAR SINKS DETAILED SPECIFICATIONS

**EUB4S72-2D**  
**EUB4S84-2D**  
**EUB4S96-2D**

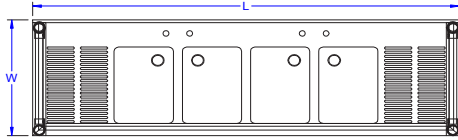

**EUB2S48-1RD**  
**EUB2S48-1LD**

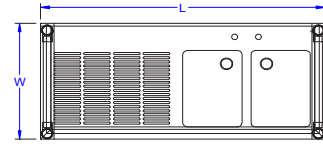

**EUB3S60-2D**  
**EUB3S72-2D**  
**EUB3S84-2D**  
**EUB3S96-2D**

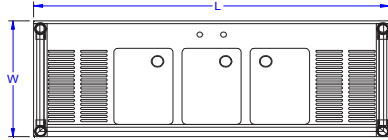

**EUB2S48-2RD**

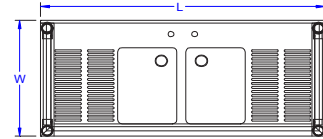

**EUB3S48-1RD**  
**EUB3S48-1LD**  
**EUB3S60-1RD**  
**EUB3S60-1LD**

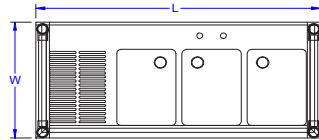

**EUB2S36-1RD**  
**EUB2S36-1LD**

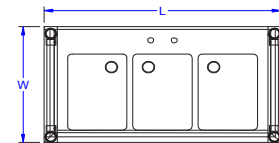
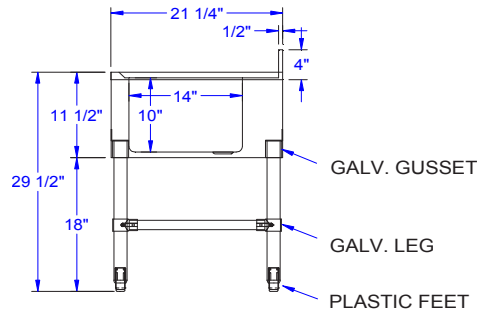
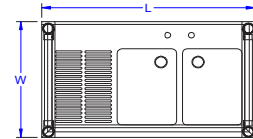

**EUB3S40**



## UNDERBAR DRAIN BOARDS

RD = RIGHT DRAIN BOARD  
LD = LEFT DRAIN BOARD

| MODEL #     | LENGTH | WIDTH | DB  | HEIGHT | WT. (LBS) |
|-------------|--------|-------|-----|--------|-----------|
| EUB2S36-1RD | 36"    | 21"   | 12" | 30"    | 41        |
| EUB2S36-1LD | 36"    | 21"   | 12" | 30"    | 41        |
| EUB2S48-1RD | 48"    | 21"   | 24" | 30"    | 69        |
| EUB2S48-1LD | 48"    | 21"   | 24" | 30"    | 69        |
| EUB2S48-2D  | 48"    | 21"   | 13" | 30"    | 69        |
| EUB3S40     | 40"    | 21"   | -   | 30"    | 60        |
| EUB3S48-1RD | 48"    | 21"   | 13" | 30"    | 75        |
| EUB3S48-1LD | 48"    | 21"   | 13" | 30"    | 75        |
| EUB3S60-1RD | 60"    | 21"   | 25" | 30"    | 92        |
| EUB3S60-1LD | 60"    | 21"   | 25" | 30"    | 92        |
| EUB3S60-2D  | 60"    | 21"   | 13" | 30"    | 92        |
| EUB3S72-2D  | 72"    | 21"   | 19" | 30"    | 102       |
| EUB3S84-2D  | 84"    | 21"   | 25" | 30"    | 109       |
| EUB3S96-2D  | 96"    | 21"   | 31" | 30"    | 124       |
| EUB4S72-2D  | 72"    | 21"   | 13" | 30"    | 104       |
| EUB4S84-2D  | 84"    | 21"   | 19" | 30"    | 120       |
| EUB4S96-2D  | 96"    | 21"   | 25" | 30"    | 135       |

WEIGHTS ARE SUBJECT TO ADDITIONAL PACKAGING

SOME UNITS SHIP UNASSEMBLED FOR REDUCED SHIPPING COST. ALL DIMENSIONS ARE TYPICAL. TOLERANCE +/- .500"  
John Boos & Co. is constantly engaged in a program of improving products and therefore reserves the right to change specifications without prior notice.