

F-2001M_H(3)

MODULAR FLAKER ICE MACHINE

Item # _____

Project: _____

Qty: _____
 *AutoCad available on KCL

F-2001M_H(3)

7/14

Item #13340

FLAKER DIMENSIONS

W x D x H

F-2001M_H(3)
 30 x 27^{1/2} x 34^{7/16}



B-500

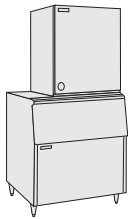

B-700

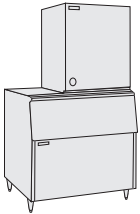

B-800

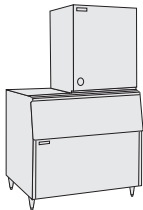

B-900

Also available on Large Bins:
 B-1150SS
 B-1300SS
 B-1500SS
 B-1650SS

*FLAKED ICE DIMENSIONS

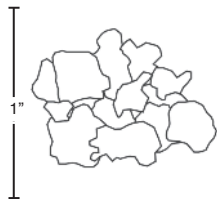

*approximate size, image not to scale



F-2001MWH

Water-Cooled
 Shown on an optional
 B-900

F-2001MRH

Remote 1 Phase

F-2001MRH3

Remote 3 Phase

- Up to 2030 lbs. of ice production per 24 hours
- Durable stainless steel exterior
- Advanced CleanCycle24® Design
- Removes sediment
- Cleaner ice
- Longer life and easy maintenance
- R-404A Refrigerant



Warranty

Valid in United States, Canada, Puerto Rico, & U.S. Territories. Contact factory for warranty in other countries.

Three Year - Parts & Labor on entire machine. (Serial numbers Vxxxxx) and after.)

Five Year - Parts on: Compressor, air-cooled condenser.



Hoshizaki

F-200IM_H(3) MODULAR FLAKER ICE MACHINE

DIMENSIONS
W x D x H
F-200IM_H(3)
30 x 27^{1/2} x 34^{7/16}

- Water-cooled
- Remote Air-cooled 1 Phase
- Remote Air-cooled 3 Phase

WATER-COOLED

| Water Temp° F. | 50° | 70° | 90° |
|----------------|------|-------------|------|
| Air Temp° F. | | | |
| 70° | 2030 | 1955 | 1915 |
| 80° | 1875 | 1835 | 1795 |
| 90° | 1760 | 1642 | 1685 |

REMOTE AIR-COOLED 1 PHASE

| Water Temp° F. | 50° | 70° | 90° |
|----------------|------|-------------|------|
| Air Temp° F. | | | |
| 70° | 1990 | 1930 | 1880 |
| 80° | 1825 | 1775 | 1730 |
| 90° | 1685 | 1592 | 1595 |

REMOTE AIR-COOLED 3 PHASE

| Water Temp° F. | 50° | 70° | 90° |
|----------------|------|-------------|------|
| Air Temp° F. | | | |
| 70° | 2010 | 1950 | 1895 |
| 80° | 1845 | 1795 | 1750 |
| 90° | 1700 | 1608 | 1610 |

UTILITY CONSUMPTION

| Model Number | KWH per 100 LBS. 90/70 | Potable Water Gal. per 100 lbs. |
|--------------|---------------------------|---------------------------------------|
| F-2001MWH | 3.68 | 12.0 |
| F-2001MRH | 4.19 | 12.0 |
| F-2001MRH3 | 4.33 | 12.0 |

SPECIFICATIONS

| Model Number | Amperage | Min. Circuit Ampacity | Shipping Weight |
|--------------|----------|--------------------------|--------------------|
| F-2001MWH | 16.94 | 30 | 342 lbs. |
| F-2001MRH | 19.94 | 30 | 360 lbs. |
| F-2001MRH3 | 18.14 | 20 | 360 lbs. |

STORAGE BINS

| Model Number | Application Capacity | ARI-Rated Capacity |
|--------------|----------------------|--------------------|
| B-500 | 500 lbs. | 360 lbs. |
| B-700 | 700 lbs. | 550 lbs. |
| B-800 | 800 lbs. | 600 lbs. |
| B-900 | 900 lbs. | 660 lbs. |
| B-1150 | 1150 lbs. | N/A |
| B-1300 | 1275 lbs. | N/A |
| B-1500 | 1490 lbs. | N/A |
| B-1650 | 1605 lbs. | N/A |

ELECTRICAL & PLUMBING/F-200IM_H(3)

- 208-230/60/1 (3 wire dedicated neutral for 115V)
- 3/8" OD copper or equivalent independent water supply with 1/4" nominal ID minimum
- 3/4" FPT independent drain connection



ISO 9001-15014001

© HOSHIZAKI AMERICA, INC.

618 Hwy. 74 S., Peachtree City, GA 30269

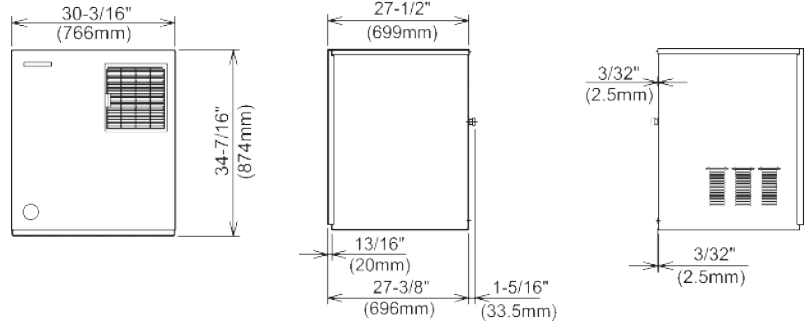

FRONT VIEW

LEFT SIDE VIEW

RIGHT SIDE VIEW

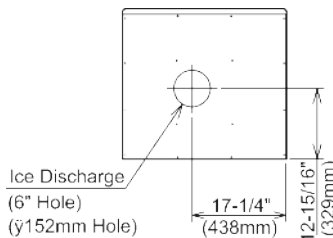

ICE DROP ZONE

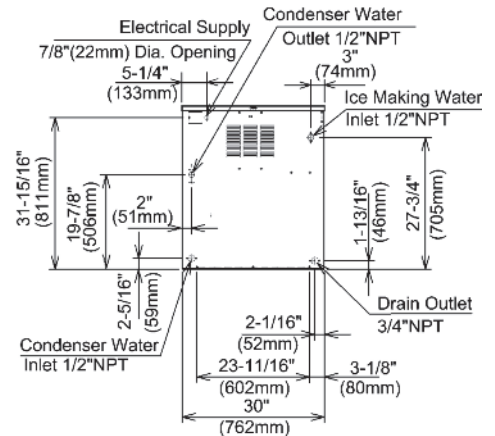

WATER-COOLED UNIT

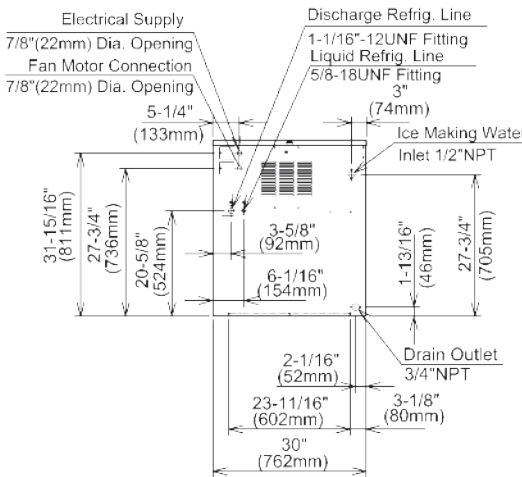

REMOTE AIR-COOLED UNIT

URC-22F Remote Condenser (Sold Separately)
For Use with F-2001MRH / F-2001MRH3

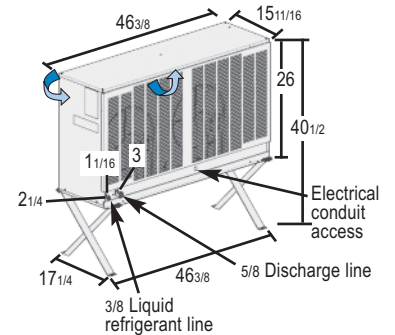

Voltage supply for the URC Remote Condenser is supplied from the Ice Maker. No additional circuit is required.

Pre-Charged Tubing Kits (Sold Separately)
20' R404-20610
35' R404-35610
55' R404-55610

OPERATING LIMITS

- Ambient Temp Range 45 - 100°F
- Water Temp Range 45 - 90°F
- Water Pressure 10 - 113psig
- Voltage Range 187 - 253V

SERVICE

- Panels easily removed and all components accessible for service.
- Removable/cleanable air filter.

