

# Sandwich Prep



**FLP-45-12**

Height 41.69" w/casters  
 Length 45"  
 Depth 30.38"



**FLP-59-16**

Height 41.69" w/casters  
 Length 59"  
 Depth 30.38"



**FLP-72-20**

Height 41.69" w/casters  
 Length 72"  
 Depth 30.38"

## Features

- Stainless steel top, front, and sides
- Aluminum interior lining prevents corrosion
- Foamed in place high density CFC free polyurethane foam insulation provides a solid structure and low energy consumption
- Self closing doors with safety stop at 120°
- Heavy duty chrome plated hinges with recessed handles
- Reinforced adjustable heavy duty epoxy coated shelves
- 6" heavy duty casters
- Hermetic seal with vinyl magnetic gasket keyed into a thermal breaker
- 1/6 size polypropylene pans
- 12" wide NSF approved polyethylene cutting board
- Forced air evaporator for rapid temperature "Pull Down"
- Self contained heavy duty 134a condensing unit
- UL Classified to ANSI/NSF 7



**FLP-27-8**

Height 41.69" w/casters  
 Length 27.5"  
 Depth 30.38"

Model No.	Description	Voltage	Amps	Temp	HP	Est. Ship Weight
FLP-27-8	1 Door/8 Pans	115	4.5	33°F - 41°F	1/5	245#
FLP-45-12	2 Doors/12 Pans	115	7	33°F - 41°F	1/4	366#
FLP-59-16	2 Doors/16 Pans	115	8.5	33°F - 41°F	1/3	388#
FLP-72-20	3 Doors/20 Pans	115	11	33°F - 41°F	1/2	445#



# Technical Data / Sandwich Prep



Model #	FLP-27-8	FLP-45-12	FLP-59-16	FLP-72-20
<b>Outside Dimensions</b>				
Depth	30.375"	30.375"	30.375"	31"
Length	27.5"	45"	59"	72"
Height w/casters	41.69"	41.69"	41.69"	41.69"
Door Size	27"L x26"H	22"L x26"H	27"L x26"H	23.44"x26"
Door Type	1 swing	2 swing	2 swing	3 swing
<b>Inside Dimensions</b>				
Depth	24.625"	24.625"	24.625"	24.625"
Length	23.5"	41"	55"	72"
Height	26"	26"	26"	26"
Cutting Board Size	12" x 27.5"	12" x 45"	12" x 59"	12" x 72"
# of Pans	8	12	16	20
# of Shelves	2	4	4	6
Shelf Size	16.81" x 22.56"	16.81" x 19.87"	16.81" x 26.87"	(4)16.81"x 21.5" (2)16.81"x 23.31"
Capacity: Cubic Foot	6.6	11.6	15.7	18.5
<b>Specifications</b>				
Operating Temperature	33°F-41°F	33°F-41°F	33°F-41°F	33°F-41°F
Refrigerant	134a	134a	134a	134a
Compressor Size HP	1/5	1/4	1/3	1/2
Voltage	115	115	115	115
Amperage	4.5	7.0	8.5	11
Cord and Plug	yes	yes	yes	yes
<b>Shipping Dimensions</b>				
Depth	34"	34"	34"	34"
Length	31"	49"	63"	76"
Height	45"	45"	45"	45"
Gross Weight lbs.	245	366	388	445
Cubic feet	25	40	51	67

**FLP-27-8**

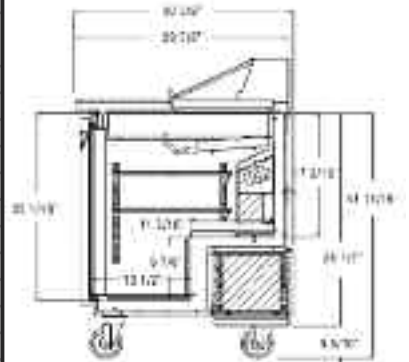
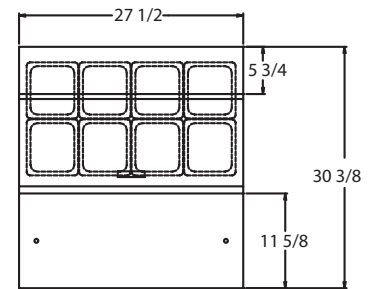

**FLP-27-8  
FLP-45-12  
FLP-59-16**

- Cases are designed to operate at 75°F and 55% relative humidity.
- Specification subject to change without notice.

