

# Single Glass Door Merchandisers



## VR-17-RE-US

74"	Height
30"	Length
25.75"	Depth
17	Cubic Ft.
481	Liters
192	Bottles (20 oz)
504	Cans (12oz)

## VR-26-US

78"	Height
30"	Length
29.5"	Depth
26	Cubic Ft.
736	Liters
355	Bottles (20 oz)
890	Cans (12oz)



## Features

- Interior and exterior constructed of heavy duty white coated steel
- Polyurethane insulation with cyclopentane as blowing agent
- Double pane glass door with Low-E protection
- Illuminated top header sign
- Externally mounted hinged glass doors
- Recessed door handle
- Heavy duty shelves with clips
- Heavy duty hinges with self closing mechanism
- Forced air evaporator for rapid temperature "Pull Down"
- Self contained heavy duty 134a condensing unit
- Energy efficient LED lighting
- UL Classified to ANSI/NSF 7

Model No.	Description	Voltage	Amps	Temp	HP	Est. Ship Weight
VR-17-RE-US	1 Door/3 Shelves	115	4.4	32°F - 39°F	1/4	250#
VR-26-US	1 Door/4 Shelves	115	5.8	32°F - 39°F	1/3	498#

# Technical Data / Single Glass Door



Model #	VR-17-RE-US	VR-26-US
<b>Outside Dimensions</b>		
Depth	25.75"	29.5"
Length	30"	30"
Height	74"	78"
Door Size	30"x47.75"	30.625"x52.5"
Door Type	1 swing	1 swing
<b>Inside Dimensions</b>		
Depth	21.75"	25.75"
Length	25.25"	26.5"
Height	54.75"	61.25"
Shelf Size	24.5"x19.5"	25.69"x24"
# of Shelves	3	4
Capacity: Cubic Foot	17	26
<b>Specifications</b>		
Operating Temperature	32°F-39°F	32°F-39°F
Refrigerant	134a	134a
Compressor Size HP	1/4	1/3
Voltage	115	115
Amperage	4.4	5.8
Cord and Plug	yes	yes
<b>Shipping Dimensions</b>		
Depth	30"	34"
Length	34"	34"
Height	80"	82"
Gross Weight lbs.	250	498
Cubic feet	47	56

- Cases are designed to operate at 75°F and 55% relative humidity.
- Specification subject to change without notice.

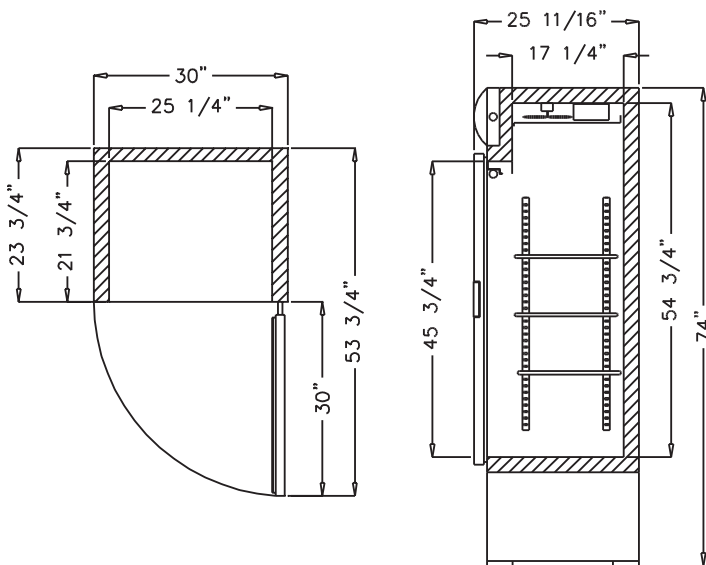

**VR-17-RE-US**

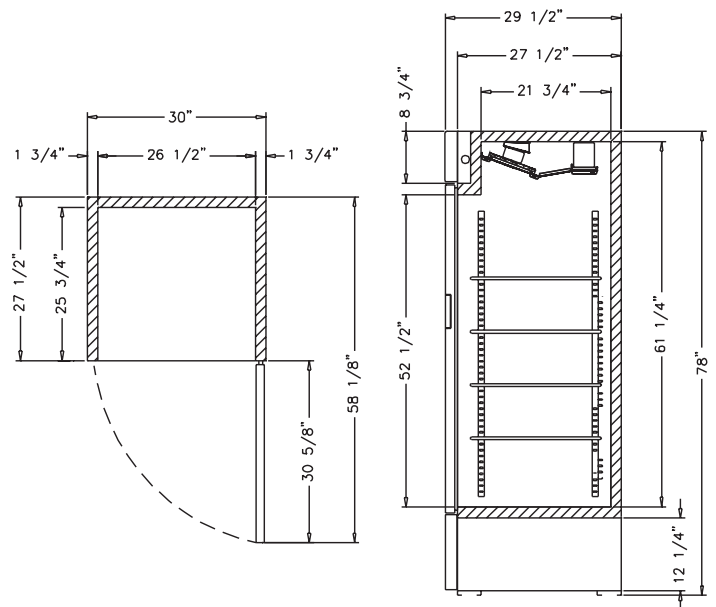

**VR-26-US**