

R-290 Glass Door Merchandiser



DECK-12-HC

Height	62"
Length	25.63"
Depth	22.75"
Cubic Ft.	12
Liters	340
Bottles (20 oz)	168
Cans (12oz)	384



R 290 HYDROCARBON REFRIGERANT GAS

The innovative HC model uses hydrocarbon R-290 as the refrigerant, which has no global warming potential (GWP) and is the first of its kind in the world with UL and NSF approval, in compliance with all safety and sanitation norms.

Moreover, the HC model is an ENERGY STAR® qualified refrigerator thanks to its low energy consumption.

FOGEL once again shows its commitment to sustainability by innovating with environmentally friendly refrigerators while increasing product value.

*** R-290 (propane grade refrigerant)**

Features

- Hydrocarbon R-290 refrigerant, which is environmentally friendly and makes the HC-12 a greener cooler
- ENERGY STAR® (Deck-12-HC) qualified model due to its high energy efficiency
- Electronic control with energy saving button and three different temperature range settings
- Double pane glass door with Low-E protection to avoid condensation.
- 4 Heavy duty adjustable shelves
- Robust body made of pre-painted galvanized steel
- 1/4 HP heavy duty condensing unit for R-290, with easy access for service
- Polyurethane insulation with cyclopentane as blowing agent
- Energy efficient LED lighting

Model No.	Description	Voltage	Amps	Temp	HP	Est. Ship Weight
DECK-10-HC	1 Door/3 Shelves	115	3.3	32°F - 39°F	1/4	225#
DECK-12-HC	1 Door/3 Shelves	115	4.2	32°F - 39°F	1/4	255#
DECK-19-HC	1 Door/4 Shelves	115	6.0	32°F - 39°F	1/3	518#

Technical Data / R-290 Glass Door Merchandiser



Model #	DECK-10-HC	DECK-12-HC	DECK-19-HC
Outside Dimensions			
Depth	22.75"	22.75"	25.75"
Length	25.63"	25.63"	28.25"
Height	54"	62"	79"
Door Size	25.25"x39.19"	25.25"x47.19"	28"x64.69"
Door Type	1 swing	1 swing	1 swing
Inside Dimensions			
Depth	19"	19"	22"
Length	22"	22"	24.75"
Height	36.5"	44.5"	62"
Shelf Size	21.75"x17.5"	21.75"x17.5"	21.75"x17.5"
# of Shelves	3	4	5
Capacity: Cubic Foot	10	12	19
Specifications			
Operating Temperature	32°F-39°F	32°F-39°F	32°F-39°F
Refrigerant	134a	134a	134a
Compressor Size HP	1/4	1/4	1/3
Voltage	115	115	115
Amperage	3.3	4.2	6
Cord and Plug	yes	yes	yes
Shipping Dimensions			
Depth	27"	27"	30"
Length	30"	30"	34"
Height	62"	69"	85"
Gross Weight lbs.	225	255	518
Cubic feet	29	32	50

- Cases are designed to operate at 75°F and 55% relative humidity.
- Specification subject to change without notice.

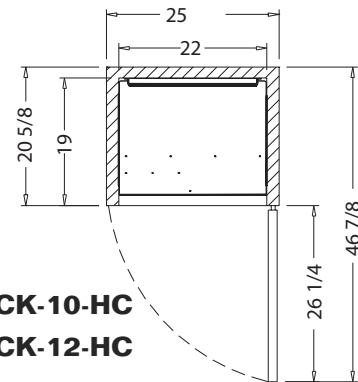

**DECK-10-HC
DECK-12-HC**

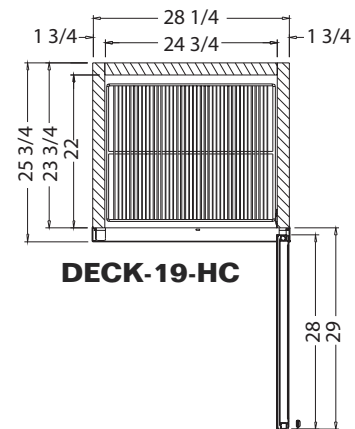

DECK-19-HC

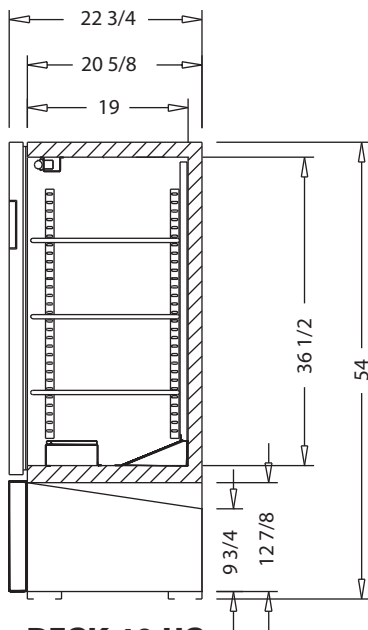

DECK-10-HC

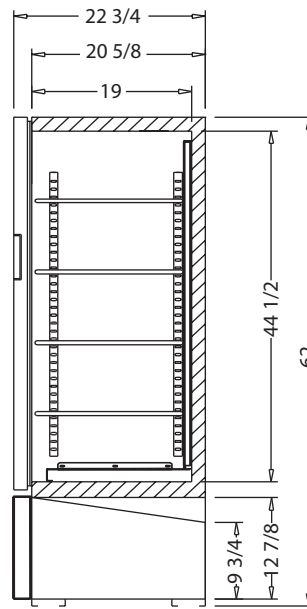

DECK-12-HC

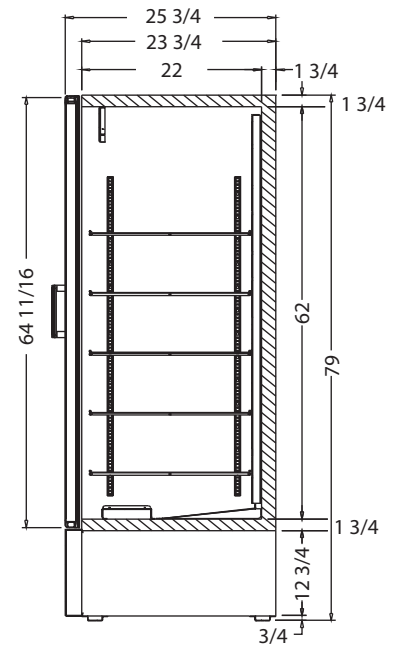

DECK-19-HC

