

Project

Date

Models
Frosty 2
Frosty 3

Item#

Quantity



model Frosty 2



model Frosty 3

FEATURES

- Large-size, high-performance equipment, for slushes, sherbets and other frozen products.
- Two or three large, 3.2 gallon (12 L) bowls.
- Indoor and outdoor use.
- The double mixing system prevents ice accumulation, for optimum product's consistency.
- Cold light illumination with LED.
- Lighted cover.
- Adjustable consistency.
- Efficient safety mechanism is activated when cover is lifted. All moving parts automatically and immediately stop.
- Transparent bowls encourage impulse purchasing.
- LED illumination system.
- Air cooling.
- Manual control keypad.
- All models are certified NSF-6 safe for milk.



FROSTY FROZEN GRANITA DISPENSERS

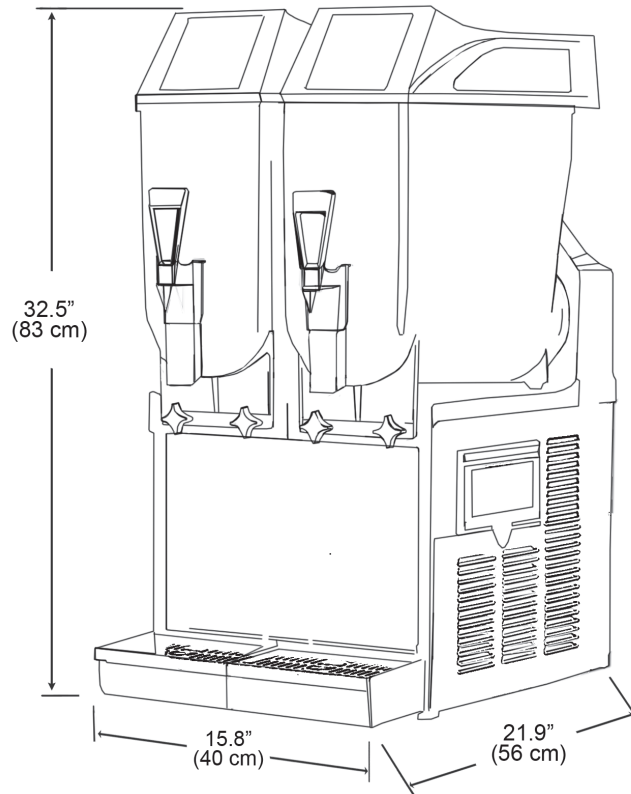

model Frosty 2

NSF-6



MODELS & SPECIFICATIONS

Model	Description	Electrical	Product Dimensions (H x W x D)	Ship Dimensions (H x W x D)	Product Weight	Ship Weight
Frosty 2 (1206-010)	(2) 3.2 gallon (12 L) tanks, 6.3 gallon (24 L) total capacity, black finish	115V / 60 Hz 1.05 kW 11 A / 1 Ph	32.5" x 15.8" x 21.9" (83 cm x 40 cm x 56 cm)	34" x 44" x 75" (86 cm x 112 cm x 191 cm)	117 lbs. (53 kg)	123 lbs. (56 kg)
Frosty 3 (1206-011)	(3) 3.2 gallon (12 L) tanks, 9.5 gallon (36 L) total capacity, black finish	115V / 60 Hz 1.35 kW 13.2 A / 1 Ph	32.5" x 23.6" x 21.9" (83 cm x 60 cm x 56 cm)	26" x 47" x 75" (66 cm x 119 cm x 191 cm)	172 lbs. (78 kg)	198 lbs. (90 kg)

Refrigeration: R404

Note: Operate at room temperature between 75 - 90° F (24 and 32° C).

Note: Clearance of 8" (20 cm) required on all sides.

Note: Mixture must maintain a sugar content between 12 -14%; a lower concentration could seriously damage the mixing parts and gear motors.