

aluminum

MOBILE SHELVING UNITS



- also know as “Queen Mary Carts”
- user configurable shelving.
- complete with heavy duty casters for mobility.
- one piece sheet design.
- easy “lock bushing” assembly.
- solid adjustable shelves.
- non-rustable aluminum.
- high strength extruded aluminum posts.
- smooth flat surface easy to clean.
- optional bumpers available.



aluminum

MOBILE SHELVING UNITS

Prairie View Industries, Inc.
FOOD SERVICE

FEATURES

- also know as "Queen Mary Carts"
- user configurable shelving.
- complete with heavy duty casters for mobility.
- one piece sheet design.
- easy "lock bushing" assembly.
- solid adjustable shelves.
- non-rustable aluminum.
- high strength extruded aluminum posts.
- smooth flat surface easy to clean.
- optional bumpers available.

DETAILS AND SPECIFICATIONS

- holds up to 400 lbs. per shelf.
- available shelf sizes are 20" or 24" wide.
- available shelf sizes are 36", 48" or 60" long.
- available post sizes are 54" or 66" in length.
- marine edge 1/8th inch.
- ships with shelves, posts, casters & lock bushings.
- UPS shippable (ships "knocked down").

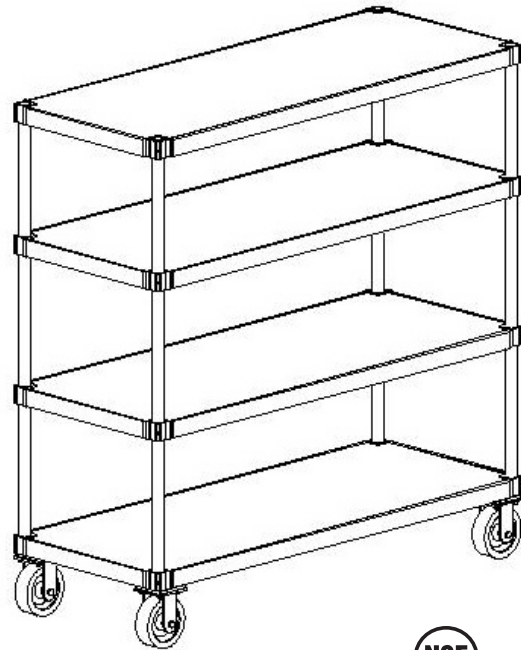

MOBILE SHELVING UNITS		
Model Number	Size (W-H-L)	Price \$
N204836-4-CHL2	20" X 48" X 36"	275.04
N204848-4-CHL2	20" X 48" X 48"	309.60
N204860-4-CHL2	20" X 48" X 60"	347.04
N206036-4-CHL2	20" X 60" X 36"	280.80
N206048-4-CHL2	20" X 60" X 60"	315.36
N206060-4-CHL2	20" X 60" X 60"	352.80
N244836-4-CHL2	24" X 48" X 36"	292.32
N244848-4-CHL2	24" X 48" X 48"	329.76
N244860-4-CHL2	24" X 48" X 60"	367.20
N246036-4-CHL2	24" X 60" X 36"	298.08
N246048-4-CHL2	24" X 60" X 48"	335.52
N246060-4-CHL2	24" X 60" X 60"	372.96

Ships with heavy duty casters, 2 locking and 2 non locking. Optional bumpers available.

Item #:

Model #:

Project #:

Quantity #: