

aluminum

SHELVING



- one piece sheet design.
- easy “lock bushing” assembly.
- solid adjustable shelves.
- non-rustable aluminum.
- high strength extruded aluminum.
- smooth flat surface easy to clean.



aluminum

SHELVING

Prairie View Industries, Inc.
FOOD SERVICE

Item #:

Model #:

Project #:

Quantity #:

FEATURES

- one piece sheet design.
- easy "lock bushing" assembly.
- solid adjustable shelves.
- non-rustable aluminum.
- high strength extruded aluminum.
- smooth flat surface easy to clean.

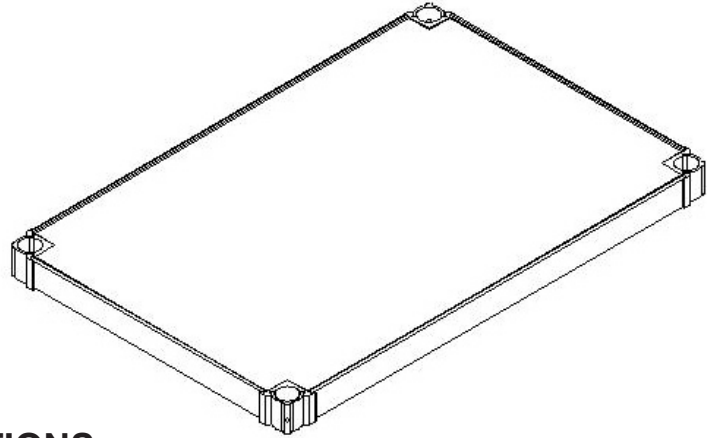

DETAILS AND SPECIFICATIONS

- holds up to 400 lbs. per shelf.
- marine edge 1/8th inch.
- ships with shelf, lock bushings, locking screws, wrench.
- 4 posts (30", 60" or 72" sizes)
- 8 post round plastic caps
- UPS shippable.



SHELVING			
Model Number	Size (W-H-L)	Weight #	Price \$
NS1824	18" X 2" X 24"	6	34.56
NS1836	18" X 2" X 36"	8	39.60
NS1848	18" X 2" X 48"	10	49.68
NS1860	18" X 2" X 60"	12	58.32
NS2024	20" X 2" X 24"	7	36.00
NS2036	20" X 2" X 36"	9	43.20
NS2048	20" X 2" X 48"	11	51.84
NS2060	20" X 2" X 60"	13	61.20
NS2424	24" X 2" X 24"	8	41.76
NS2430	24" X 2" X 30"	9	46.08
NS2436	24" X 2" X 36"	10	47.52
NS2448	24" X 2" X 48"	12	56.88
NS2460	24" X 2" X 60"	14	66.24
Optional posts, casters and custom size shelves available upon request.			