

E**COUNTERTOP TILTING
SELF-CONTAINED ELECTRIC
STEAM JACKETED KETTLE**JOB NAME: _____
ITEM NO.: _____
NO. REQUIRED: _____**MODELS:**
 FT-6CE
 FT-10CE
 FT-12CE**CAPACITY:**
 FT-6CE 6-Gallons 23 liters
 FT-10CE 12-Gallons 38 liters
 FT-12CE 10-Gallons 46 liters

FT-6CE Shown

DESCRIPTION:

Kettle will be constructed of welded satin finish, type 316, stainless steel. The kettle will be jacketed by an outer kettle, which encloses the heating element, water and antifreeze required to generate steam. Heating element can be easily removed for service and will automatically shut off when kettle is tilted to prevent element damage.

Kettle will be equipped with tilt handle, heat-proof knob and tilt lock. Water Tight Controls will be integrally mounted to the kettle control console and include an on-off switch, solid state temperature controller with pilot light, low water shut off light, pressure/vacuum gauge, pressure safety valve, and air bleed vent.

Kettle will operate in a temperature range of approximately 100° to 298°F (38°-148°C) at a pressure not to exceed 50 PSI (305kg/cm²). Mounting base will include kettle mounting lugs consealed inside a rectangular enclosure.

OPERATION WILL BE BY:

Electrically, self-generating closed steam system equipped for operation on:

- 208 VAC, 1 pH or 3 pH, 50/60 Hz.
 - 240 VAC, 1 pH or 3 pH, 50/60 Hz.
 - 480 VAC, 3 pH, 50/60 Hz.*
 - 220/380 VAC, 3 pH, 4 wire, 50Hz.
 - 240/415 VAC, 3 pH, 4 wire, 50Hz.
 - Other Electrical Connections, Consult Factory.
- *Optional at extra cost.

OPTIONAL AT EXTRA COST:

- One-Piece Lift-Off Stainless Steel Cover
- Stainless Steel Wire Basket
- Vegetable Strainer
- 12" High Stainless Steel Stand (p/n: 97-6375)
- 20" High Stainless Steel Stand (p/n: 91-5153)
- 21" High Stainless Steel Stand with Sink/Drain (p/n: 91-5154)

ELECTRICAL CHARACTERISTICS

MODEL	pH	208 VAC		240 VAC		480 VAC		220/380 VAC		240/415 VAC	
		kW	AMP	kW	AMP	kW	AMP	kW	AMP	kW	AMP
FT-6CE	1	7.5	36.0	7.5	31.2	---	---	---	---	---	---
	OR										
FT-10CE	3	7.5	20.8	7.5	18.0	7.5	9.0	7.5	11.4	7.5	10.4
	1	12.0	57.7	12.0	50.0	12.0	14.4	12.0	18.2	12.0	16.7
FT-12CE	OR										
	3	12.0	33.3	12.0	28.8	12.0	14.5	12.0	31.5	12.0	28.9

The manufacturer reserves the right to modify materials and specifications without notice.

SPEC SHEET: S-2261C
01/13FOOD SERVICE EQUIPMENT
Countertop Tilting Kettles**MARKET FORGE**
INDUSTRIES INC.35 Garvey Street • Everett • MA • 02149
Tel: (617) 387-4100 • Fax: 1-800-227-2659 (Ex. MA) • (617) 387-4456 (MA and Overseas)
E-Mail: CUSTSERV@mfii.com • Website: www.mfii.com

A City Discount

E**COUNTERTOP TILTING
SELF-CONTAINED ELECTRIC
STEAM JACKETED KETTLE**

JOB NAME: _____

ITEM NO.: _____

NO. REQUIRED: _____

MODEL	CAPACITY		A	B	C	D	E	G	H	J	L	P	O
FT-6CE	6-Gallon	in	12	14.5	24.5	15.25	33.5	14.75	22	6.375	27.75	12.5	10
	23 liters	mm	305	368	692	387	851	374	559	162	705	317	254
FT-10CE	10-Gallon	in	15.75	15	25.75	17.25	33	14.88	26	6.125	28	15	12.75
	38 liters	mm	400	381	654	438	838	377	660	156	711	381	324
FT-12CE	12-Gallon	in	16	17	28	18	36.875	14.375	26	5.75	30	15	12.75
	45 liters	mm	406	432	711	458	937	365	660	146	762	381	324

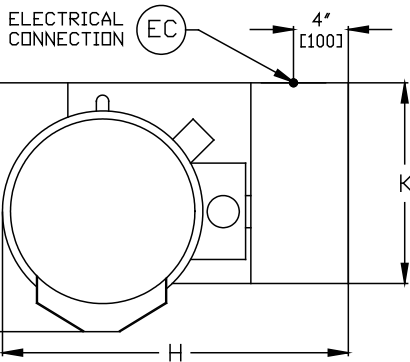

CAUTION:
When adding water to kettle, have water analyzed to make sure hardness is no greater than 2.0 grains and pH level is within the range of 7.0-8.5. If water fails to meet these standards, add ionized or distilled water with sodium. **EQUIPMENT FAILURE CAUSED BY INADEQUATE WATER QUALITY IS NOT COVERED UNDER WARRANTY**

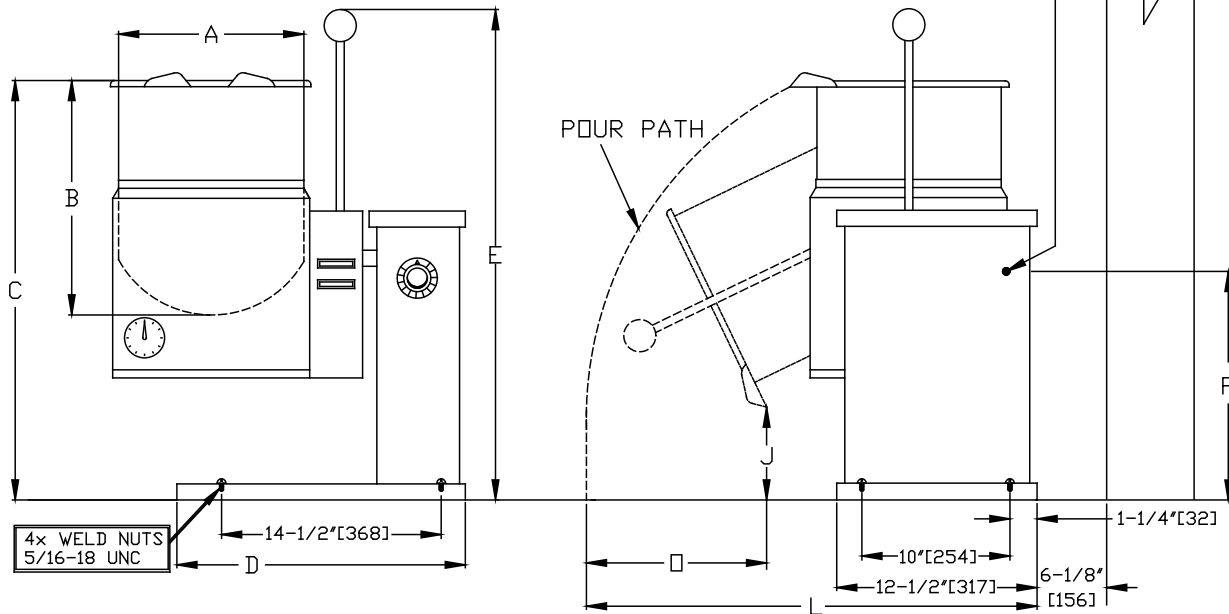

It is our policy to build equipment which is design certified by N.S.F., A.S.M.E. and C.S.A. However, a continuing program of product improvement makes it necessary to submit new models to the agencies as they are developed and consequently not all models bear the appropriate agency labels at all times.

SPEC SHEET: S-2261C
01/13FOOD SERVICE EQUIPMENT
Countertop Tilting Kettles**MARKET FORGE**
INDUSTRIES INC.

PRINTED IN U. S. A.

35 Garvey Street • Everett • MA • 02149
Tel: (617) 387-4100 • Fax: 1-800-227-2659 (Ex. MA) • (617) 387-4456 (MA and Overseas)
E-Mail: CUSTSERV@mfii.com • Website: www.mfii.com

A City Discount