



Model #ABC-36

Standard Features – Horizontal Bottle Cooler #ABC-36

- Environmentally safe R290 refrigerant
- Durable black coated steel exterior
- Painted aluminum interior
- Foamed-in-place polyurethane insulation
- (1) Locking lid
- 8.5 cu. ft. interior
- Digital temperature controller
- 115V; 1/6 HP
- ETL listed. Conforms to UL STD. 471, Certified to CSA STD. C22. 2No.120
- Conforms to NSF/ANSI STD. 7.

Construction

Exterior Material	Black Coated Steel
Interior Material	Painted Aluminum
Insulation Material	Foamed-In-Place Polyurethane

Cooling

Temperature Range	33°F-40°F
Refrigerant	R290
Max. Ambient Temperature	90°F
Defrosting	Automatic
Temperature Controller	Digital
Horsepower	1/4

Electrical

Voltage	115
Amps	1.1
Hz	60
Phase	1
Plug Type	NEMA-5-15P
Electrical Cord Length	90"

Dimensions

Exterior Dimensions	36 "W x 28"D x 34-1/4"H
Interior Dimensions	31-7/8"W x 23"D x 15-3/4"H
Shipping Dimensions	39"W x 32-3/4"D x 41-3/4"H
Net Volume	8.5 cu. ft.
Net Weight	128 lb.
Gross Weight	152 lb.



PLAN VIEW

Front View

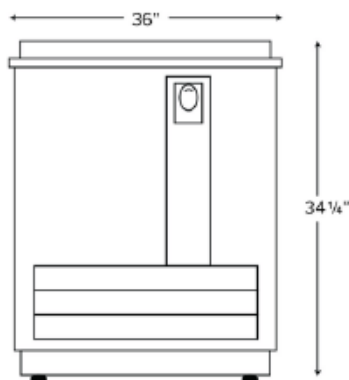

Side View

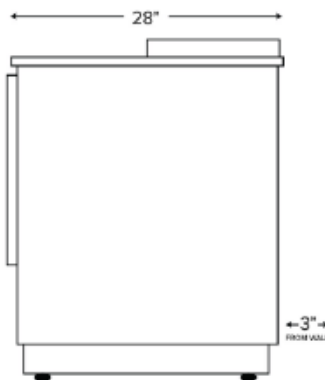

Top View

