

### Standard Features – 36" Cheese Melter Natural Gas

#### Model #ACM-36



ETL Safety & Sanitation Listed

- Stainless steel front and sides
- Counter or wall mount
- Natural gas ceramic infrared burner for better and even heat distribution
- Total 30,000 BTUs
- Standing pilot ignition system
- 3 position rack adjustments
- Chrome plated wiring grid rack
- Removable oil collector for easy cleaning
- 3/4 " NPT rear gas connection



Model #	Total BTU	Burners	Net Dimensions	Gross Dimensions	Net Weight	Shipping Weight
ACM-36	30,000	1	36"W X 19"W X 23"	42.5"W X 25"W X 30"H	139 lbs	196 lbs.

### PLAN VIEW

Front View

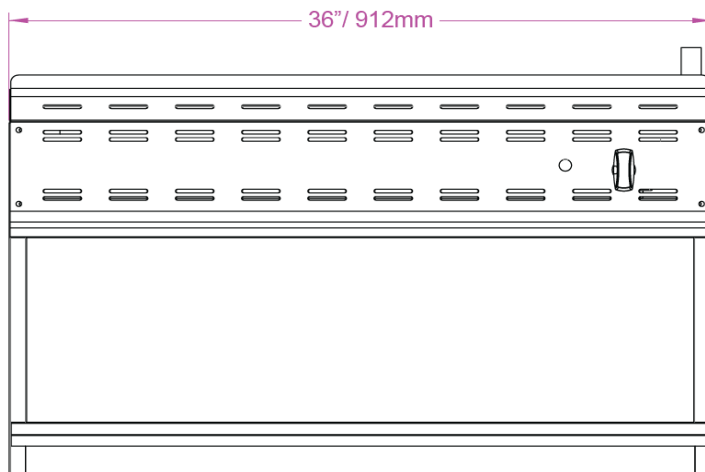

Side View

