

Standard Features – 72" Cheese Melter Natural Gas

Model #ACM-72



- Stainless steel front and sides
- Counter or wall mount
- (2) Natural gas ceramic infrared burner for better and even heat distribution
- Total 60,000 BTUs
- Standing pilot ignition system
- 3 position rack adjustments
- Chrome plated wiring grid rack
- Removable oil collector for easy cleaning
- 3/4 " NPT rear gas connection

ETL Safety & Sanitation Listed



Model #	Total BTU	Burners	Net Dimensions	Gross Dimensions	Net Weight	Shipping Weight
ACM-72	60,000	2	72"W X 19"W X 23"H	76"W X 25"W X 30"H	225 lbs	335 lbs.

PLAN VIEW

Front View

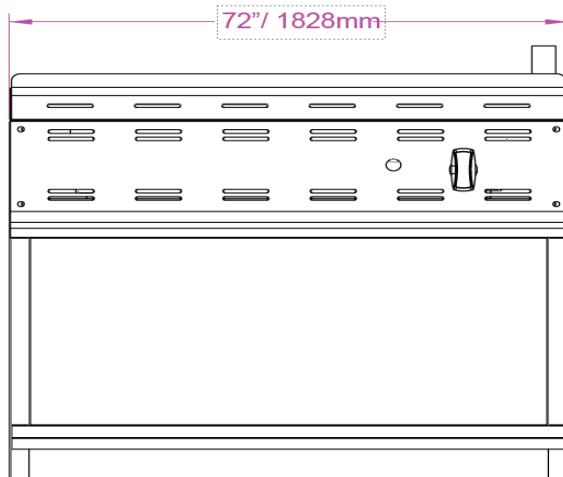

Side View

