

## Standard Features – Beer Dispenser Model #ADD-48SS



**Model #ADD-48SS**

### Cooling

Temperature Range	33°F-40°F
Refrigerant	R290
Max. Ambient Temperature	90°F
Defrosting	Automatic
Temperature Controller	Digital
Horsepower	1/5

### Electrical

Voltage	115
Amps	3
Hz	60
Phase	1
Plug Type	NEMA-5-15P
Electrical Cord Length	96"

- Holds (2) ½ kegs
- Double tap tower with 10-1/4" faucet height
- Includes 2 "D" system keg couplers
- Foamed-in-place polyurethane insulation
- (4) epoxy-coated shelf accommodates up to 90 lb.
- Environmentally-safe R290 refrigerant
- LED lights illuminate interior
- (2) locking self-closing door with recessed handles
- 115V; 1/5 HP
- ETL listed. Conforms to UL STD. 471, Certified to CSA STD. C22. 2No.120
- Conforms to NSF/ANSI STD. 7

### Construction

Exterior Material	Black coated steel
Interior Material	Painted aluminum
Insulation Material	Foamed-In-Place Polyurethane
Shelf	(4) epoxy-coated steel holds up to 90 lb.
Taps	(2) 10-1/4 faucet height

### Dimensions

Exterior Dimensions	48-3/4"W x 24-3/8"D x 35-5/8"H
Interior Dimensions	36-1/4"W x 18-1/2"D x 28-7/8"H
Shipping Dimensions	51-1/4"W x 27-1/2"D x 41-3/4"H
Tower Dimensions	16"H 3" Diameter
Net Volume	13 cu. ft.
Net Weight	231 lb.
Gross Weight	275lb.



Parts & Labor

Compressor

## PLAN VIEW

Front View  
Front View

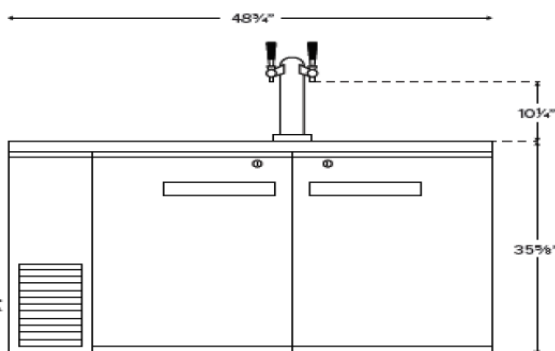

Side View  
Side View

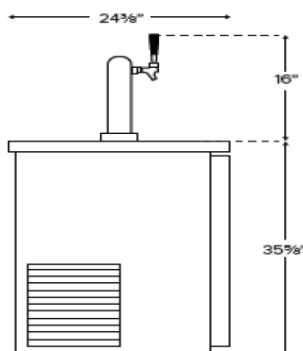

Top View  
Top View

