

Hot Food Table Natural Gas

HFT-3-NG Gas Hot Food Table

STANDARD FEATURES

- Heavy duty stainless steel openings
- Die-stamped 12" x 20" openings
- Galvanized legs with adjustable bullet ends
- Adjustable stainless steel under shelf
- Welded frame structure for best stability
- Poly cutting board 8" wide and 1/2" thick mounted on stainless steel brackets on control side of unit
- Individually controlled infinite switches for each compartment
- Red indicator light while in use
- Wells are 8" deep and lined with galvanized steel
- Each compartment is fully insulated on all sides and bottom with 1" thick insulation
- Each compartment features an individual burner rated at 3,500 BTU
- Each burner controlled by a High-Medium-Low adjustable
- Gas valve with adjustable pilot light.
- One year limited parts and labor warranty



Model HFT-3-NG

ETL Safety & Sanitation Listed



Plan View

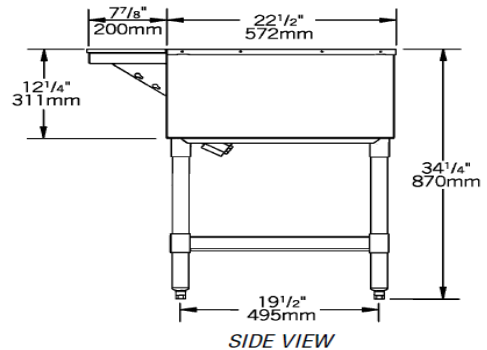
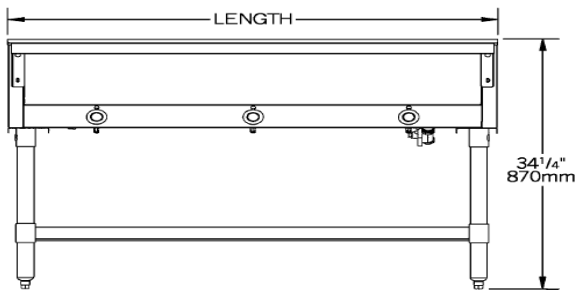
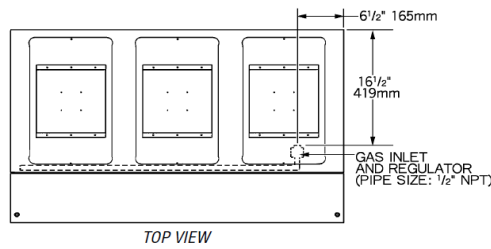

Model	Description	Total BTU/HR	Dimensions	N/W (LB)	G/W (LB)
HFT-3-NG	Hot Food Table 3-well Natural Gas	10,500	43 x 31" x 34.25"	98	125