

Hot Food Table Natural Gas



Model HFT-5-NG

ETL Safety & Sanitation Listed



HFT-5-NG Natural Gas Hot Food Table

STANDARD FEATURES

- Heavy duty stainless steel openings
- Die-stamped 12" x 20" openings
- Galvanized legs with adjustable bullet ends
- Adjustable stainless steel under shelf
- Welded frame structure for best stability
- Poly cutting board 8" wide and 1/2" thick mounted on stainless steel brackets on control side of unit
- Individually controlled infinite switches for each compartment
- Red indicator light while in use
- Wells are 8" deep and lined with galvanized steel
- Each compartment is fully insulated on all sides and bottom with 1" thick insulation
- Each compartment features an individual burner rated at 3,500 BTU
- Each burner controlled by a High-Medium-Low adjustable
- Gas valve with adjustable pilot light
- One year limited parts and labor warranty

Plan View

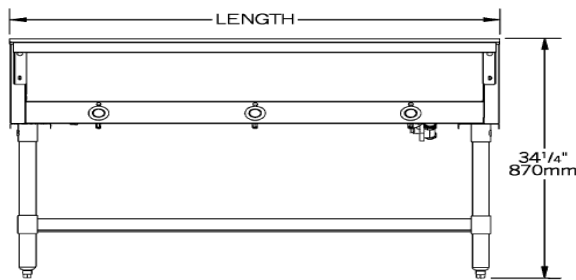

FRONT VIEW

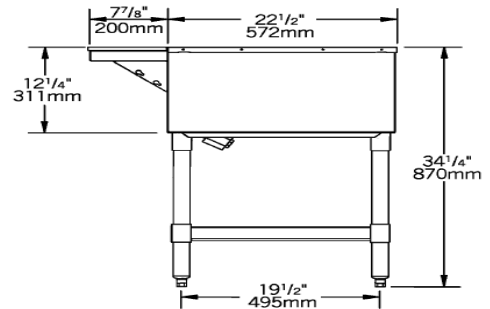

SIDE VIEW

Model	Description	Total BTU/HR	Dimensions	N/W (LB)	G/W (LB)
HFT-5-NG	Hot Food Table 5-well Natural Gas	17,500	71 x 31" x 34.25"	190	241

www.falconequipment.com

879 South 4400 West
Salt Lak City, UT 84104
888-987-7894