



Model #AF-72

### Cooling

Temperature Range	(-5°F)-2°F
Refrigerant	R290
Max. Ambient Temperature	90°F
Defrosting	Automatic
Temperature Controller	Digital
Horsepower	1-1/4

### Electrical

Voltage	115
Amps	12
Hz	60
Phase	1
Plug Type	NEMA-6-20P
Electrical Cord Length	96"

### Standard Features

- Self-closing doors with convenient stay-open feature
- Easy-to-clean 430 series stainless steel exterior
- Painted Aluminum exterior
- Temperature range of (-5)°F - 2°F
- 9 shelves included; versatile shelf slide design also accepts full size food pans
- Environmentally-safe R290 refrigerant
- Digital temperature controller with automatic defrost function
- 115V; 1 ¼ HP
- ETL Safety & Sanitation Listed
- Conforms to UL STD. 471, Certified to CSA STD. C22. 2No.120
- Conforms to NSF/ANSI STD. 7.

### Construction

Exterior Material	430 Stainless Steel
Interior Material	Painted aluminum
Insulation Material	Foamed-In-Place Polyurethane
Shelf Size	(6) 20-7/8"W x 25-3/16"D & (3) 22-1/8"W x 25-3/16"D
Shelf Material	Epoxy-Coated Steel
Shelf Load Capacity	120 lbs.

### Dimensions

Exterior Dimensions	80-7/8"W x 32-1/4"D x 82-1/2"H
Interior Dimensions	76-1/4"W x 27-1/8"D x 60-1/4"H
Shipping Dimensions	83-1/2"W x 34-3/4"D x 85-1/2"H
Net Volume	66.5 cu. ft.
Net Weight	615 lb.
Gross Weight	693 lb.



Parts & Labor

Compressor

### PLAN VIEW

Front View

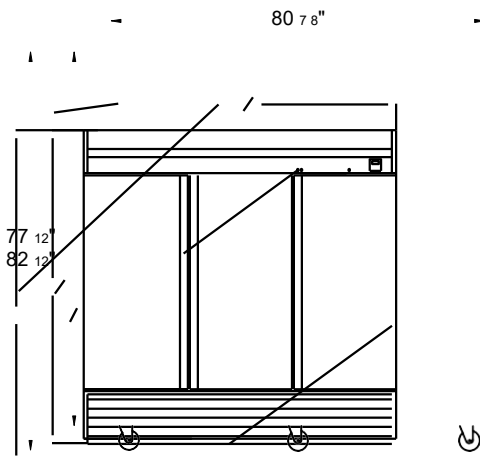

Side View

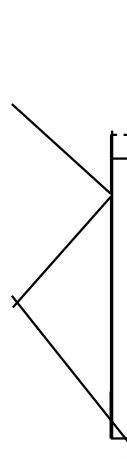

Top View

