



Model #ABC-25

Standard Features – Horizontal Bottle Cooler #ABC-25

- Environmentally safe R290 refrigerant
- Durable black coated steel exterior
- Painted aluminum interior
- Foamed-in-place polyurethane insulation
- Locking lid and removable bottle opener/cap catcher included.
- 4.1 cu. Ft. interior
- Digital temperature controller
- 115V; 1/6 HP
- ETL listed. Conforms to UL STD. 471, Certified to CSA STD. C22. 2No.120
- Conforms to NSF/ANSI STD. 7.

Construction

Exterior Material	Black Coated Steel
Interior Material	Painted Aluminum
Insulation Material	Foamed-In-Place Polyurethane

Cooling

Temperature Range	33°F-40°F
Refrigerant	R290
Max. Ambient Temperature	90°F
Defrosting	Automatic
Temperature Controller	Digital
Horsepower	1/6

Electrical

Voltage	115
Amps	2.04
Hz	60
Phase	1
Plug Type	NEMA-5-15P
Electrical Cord Length	90"

Dimensions

Exterior Dimensions	26-3/8"W x 28"D x 34-1/4"H
Interior Dimensions	22-1/4"W x 23"D x 15-3/4"H
Shipping Dimensions	30-1/4"W x 31"D x 41-3/4"H
Net Volume	4.1 cu. ft.
Net Weight	128 lb.
Gross Weight	158 lb.



PLAN VIEW

Front View

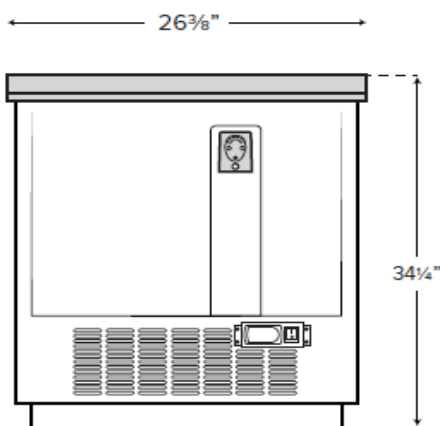

Side View

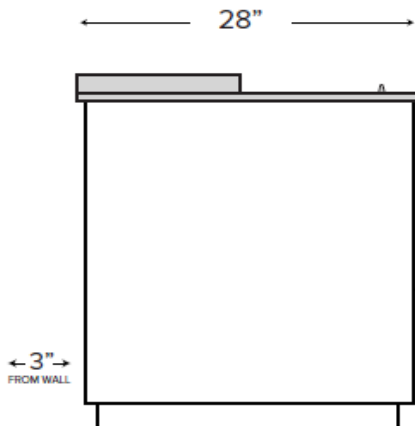

Top View

